

PLEASE NOTE:

The *Government of Canada Workplace Fit-up Standards* is an evergreen document. It is updated regularly to ensure it remains aligned with the latest direction regarding fit-up, funding accountabilities, government priorities and initiatives, as well as other factors. This version of the Standards has been updated based on the approval of the Treasury Board submission on split funding (July 2019).

The specific sections that have been revised for this update include:

- The opening Assistant Deputy Minister message
- Section A3.1: Funding Accountabilities by Occupancy Instrument Type
- Section A3.2: Fit-up Elements and Funding Accountabilities
- Section A5: Finishes
- Section A6: Costing
- Section A6.3: Additional Direct and Indirect Costs
- Section A7.1: Fit-up Cost Estimate Template, now 'Fit-up Cost Estimate and Tools'

In addition, the fit-up rates are currently being finalized and will be added to the document as well as the updated cost planning workbook when completed. We endeavour to continue revising the document based on recent feedback from other key stakeholder areas within Real Property Services and the Regions.

Thank you.

GOVERNMENT OF CANADA

Workplace Fit-up Standards



April 2021



Public Services and
Procurement Canada

Services publics et
Approvisionnement Canada

Canada

Table of Contents

Section A: General-purpose Office Space Standards

A1. Overview	A-01
A2. Approvals and Governance	A-05
A2.1 Compliance with the <i>Government of Canada Workplace Fit-up Standards</i>	A-05
A2.2 Compliance Monitoring	A-06
A2.3 Process for Approval of Non-compliance	A-08
A2.4 Submission Requirements	A-12
A2.5 Criteria for Evaluating Requests for Non-compliance	A-13
A2.6 Non-compliance Trends and Reporting	A-13
A2.7 Compliance Monitoring Form	A-14
A2.8 Business Case Template	A-15
A3. Funding Accountabilities of PSPC and Client Departments	A-19
A3.1 Funding Accountabilities by Occupancy Instrument Type	A-19
A3.2 Fit-up Elements and Funding Accountabilities	A-22
A4. Planning and Design	A-35
A5. Finishes	A-37
A5.1 Finishes	A-37
A6. Costing	A-39
A6.1 Fit-up Rates (Under Development)	A-39
A6.2 Source of Funds for Non-compliant Workplace Fit-up Elements	A-48
A6.3 Additional Direct and Indirect Costs	A-49
A6.4 Project Delivery Cost Controls	A-51
A7. Fit-up Cost Estimate and Tools	A-53
A7.1 Fit-up Cost Estimate	A-53
A7.2 The Real Property Space Assessment and Planning App	A-54

Section B: Ministerial and Deputy Head Office Accommodations

B1. Introduction	B-01
B1.1 General Information	B-01
B2. Standards	B-03
B2.1 Fit-up Elements and Funding Accountabilities	B-03
B2.2 Office and Support Space Allocations	B-05
B3. Planning	B-07
B3.1 Planning and Design	B-07
B4. Sample Detail Drawings	B-09
B4.1 Offices	B-09
B4.2 Support Spaces	B-24
B5. Costing	B-25
B5.1 Cost Estimates	B-25

Section C: Quasi-judicial Accommodations

C1. Introduction	C-01
C1.1 General Information	C-01
C1.2 Application	C-01
C2. Standards	C-03
C2.1 Fit-up Elements and Funding Accountabilities	C-03
C2.2 Office and Support Space Allocations	C-04
C3. Planning	C-07
C3.1 Planning and Design	C-07
C4. Sample Detail Drawings	C-09
C4.1 Support Space	C-09
C4.2 Typical Employee Washroom	C-12
C5. Costing	C-13
C5.1 Cost Estimates	C-13



Section D: Call/Contact Centres Accommodations

D1. Introduction	D-01
D1.1 General Information	D-01
D1.2 Application	D-01
D2. Standards	D-03
D2.1 Fit-up Elements and Funding Accountabilities	D-03
D2.2 Office and Support Space Allocations	D-05
D2.3 Standards for Furniture Panels/Screens	D-11
D3. Planning	D-13
D3.1 Planning and Design	D-13
D3.2 Sample Plan	D-14
D4. Sample Detail Drawings	D-17
D4.1 Typical Workstation Configurations	D-17
D4.2 Support Space	D-18
D5. Costing	D-25
D5.1 Cost Estimates	D-25



Glossary

Glossary	01
--------------------	----

Message from the Assistant Deputy Minister

GCworkplace is the shared vision for the Government of Canada workplace; a vision established collaboratively with your input, and supported by the Government of Canada Fit-up Standards. GCworkplace guides the delivery of workplace modernization projects and solutions offered by Public Services and Procurement Canada (PSPC) to federal organizations. Over the last five years, your support, along with the support of the Treasury Board of Canada Secretariat, has allowed us to innovate, learn, and tremendously improve our ability to provide these solutions.

GCworkplace stems from your input; it is informed by lessons learned and research on global workplace trends and innovations. At its core, workplace solutions stem from the GCworkplace vision and strive to achieve the seven dimensions you have identified: a workplace that is **flexible, healthy, efficient, inclusive, collaborative, digital and green**.

In July 2019, Treasury Board of Canada Secretariat approved a revision to fit-up funding accountability, providing PSPC with responsibility over a broader portion of office fit-up costs. For non-reimbursing clients, this new funding reduces their overall fit-up cost obligations. For PSPC, it allows for better management of office portfolio planning. We have updated the Fit-up Standards document to reflect this new accountability, which will facilitate a smoother shift to GCworkplace for all federal organizations.

While the events of 2020 have added a layer of complexity and uncertainty in some areas, they have also accelerated the adoption of a work environment previously believed by some to be many years away (e.g.: online tools, telework, and mobile capabilities). This has opened up new possibilities for how we work, and highlights the importance of the easy adaptability of a GCworkplace to our new environment.

GCworkplace is about more than just new workspaces and new furniture. It is a holistic approach to workplace modernization that supports the new way of working in a mobile, connected and high-performing public service. It is no longer about where you work, but rather what you do and how you work. It is about ensuring we are integrating our space, technology and human resource strategies to make them work for you. It is about equipping you with the right tools, processes and organizational culture to support fundamental changes in the way we live and work. It is about building something together so that we may give our very best service to Canadians.

The *Government of Canada Workplace Fit-up Standards* and the supporting tools provide the baseline for establishing innovative activity-based work environments that accommodate diverse work styles, meet accessibility requirements, support alternative work strategies, incorporate modern technology, and include sustainable design principles.

Our new environment has accelerated the need for GCworkplace and the tools are now in place to make it happen. Together, we will continue to transform the experience of working for the Government of Canada.

Stéphan Déry
Assistant Deputy Minister
Real Property Services
Public Services and Procurement Canada



Section A: General-purpose Office Space Standards



A1. Overview

Application

The *Government of Canada Workplace Fit-up Standards* apply to:

- All office accommodation under the administration of PSPC as provided to federal departments and agencies, whether reimbursing or non-reimbursing. This includes the following office space categories; general administrative, secure administrative, quasi-judicial office space, call/contact centre space as well as for ministerial and deputy head accommodation. The additional security requirements of secure administrative office space are addressed in [section A3.2](#), therefore, separate standards are not provided. Allowances for minister and deputy head accommodation, quasi-judicial office space as well as call/contact centre space are provided in sections [B](#), [C](#) and [D](#), respectively, of this standard. (**Note:** The *Government of Canada Workplace Fit-up Standards* also apply, in spirit and intent, to standard fit-up elements provided in special purpose space (SPS), although it is recognized that this space type will have special technical and fit-up requirements.)
- Alterations and/or improvements to the above-noted accommodation including:
 - Fit-up for initial occupancy;
 - Tenant service work requested and funded by the client. Tenant service work shall **NOT** result in a quality of office accommodation higher than that permitted by the *Workplace Fit-up Standards*; and
 - Fit-up of existing space for reuse by a different PSPC client. The scope of this fit-up shall take into account the functional requirements of the client, existing conditions of the previously occupied space, and the duration of the occupancy.

The *Government of Canada Workplace Fit-up Standards* do not apply to:

- Real property under the administration of Crown Corporations and other custodial departments. However, where PSPC provides optional services to departments and agencies, PSPC shall promote and recommend the application of these standards; and
- Office accommodation provided for House of Commons, Senate, Library of Parliament and Minister's Regional Offices (MROs).

All custodial departments are encouraged to adopt and apply the *Government of Canada Workplace Fit-up Standards* to support a government-wide approach.

Unless otherwise specified, all figures are in **usable** metres squared.

Requests for clarification, advice or guidance may be sent to the [Fit-up mailbox](#).

Accommodation Management Framework

PSPC's approach to fit-up is guided by the *Accommodation Management Framework* (2013). The primary messages of the framework are that client departments and agencies share responsibility with PSPC for applying standards for the quantity and quality of office accommodation, and that PSPC is funded to provide office accommodation to client departments only to the level of the *Government of Canada Workplace Fit-up Standards*. The framework states that the allocated space should be the minimum necessary to support the functional requirements of the occupant.

Fit-up Principles

The Standards respond to government programs and priorities, and are compliant with all relevant codes, life safety and accessibility standards. The following principles support social, economic and environmental sustainability, and are to be applied to the greatest extent possible.

- PSPC's Real Property Services continues to be mandated to provide affordable and sustainable office accommodation and related services for federal government departments and agencies. These services include the fit-up of office space to meet client department program requirements within the limits of this Standard.
- Fit-up, which represents a significant portion of PSPC's real property business, includes the preparation of accommodation for initial occupancy, and the alteration of existing space for reuse by a different client department or agency.
- The *Government of Canada Workplace Fit-up Standards* specify a midrange quality for fit-up elements and finishes considered to be part of a typical fit-up for general-purpose office space. This is often referred to as the standard "bundle of goods" delivered by PSPC on all fit-up projects regardless of location or client.
- The standard is quality, not cost based. In other words, the same "bundle of goods" is delivered on fit-up projects across the country, regardless of any regional cost variances. The fit-up elements and finishes incorporate the fundamental aspects of a modern, flexible, environmentally sustainable and supportive work environment.
- Controls continue to be incorporated into the process for delivering fit-up projects to help constrain costs and avoid delays to the project schedule. This includes the "two revision rule" limiting the number of revisions a client can request per design stage. (For more information on project controls, refer to [section A6.4](#).)

Standardization of fit-up projects and elements is intended to:

- achieve cost-effective and timely delivery of accommodation and accommodation services;
- clearly define accountabilities;
- improve understanding of PSPC's real property program;
- ensure equity and consistency in federal accommodation thereby facilitating relocations;
- incorporate the fundamental aspects of environmental sustainability and supportive work environments; and
- demonstrate value to Canadian citizens through improved management of federal accommodation.

Sustainability

- The fit-up of Government of Canada office space is guided by the principles of energy efficiency, minimal environmental impact, occupant health and comfort and functional performance.
- The Government of Canada encourages the use of sustainability design tools and programs such as Leadership in Energy and Environmental Design (LEED), BOMA BEST, Green Globes or other comparable green building management assessment tools.
- For interior fit-ups in existing buildings; materials selection and space designing to allow for maximum penetration of natural light in accordance with LEED Commercial Interiors certification criteria.

Universal Design for Accessibility

The *Government of Canada Workplace Fit-up Standards* provide the flexibility to create innovative workplace fit-up solutions using a common sense approach in a manner that represents best value to the Crown. Subsequently, considerations fit-up elements and material choices should extend beyond the CAN/CSA B651 accessibility standard where feasible and appropriate to ensure the establishment of a workplace that proactively ensures that workplace features are accessible to all users. This includes both those with permanent and temporary disabilities or impairments. The following are examples of elements of universal design for accessibility that can be incorporated into the typical workplace fit-up:

- Way-finding systems that are simple and intuitive, that rely on non-text cues to provide direction such as the use of flooring or walls in contrasting colours.
- Enhanced workplace signage (non-building) that can be read by those with low or no vision and located so as to maximize visibility from various angles.
- Controls and hardware such as door handles and light switches that are designed to be used by individuals with varying levels of dexterity.
- Barrier free design for all spaces in the work environment, i.e., beyond legislated requirements for accessible entranceways, corridors, washrooms and workstations.

Security

- Security requirements must be fully integrated into the planning and design of government accommodation.
- Security requirements identified by a Threat and Risk Assessment can usually be met using a combination of one or more design features including zoning of restricted access areas, entry barriers, security systems and equipment.
- Client departments are responsible for informing PSPC of their security requirements for tenant fit-up. The necessary security specifications must be included in all plans, funding requirements, requests for proposals and tender documentation for fit-up projects. Client departments should refer to the *Treasury Board Policy on Government Security*, and the *Treasury Board Operational Security Standard on Physical Security* when planning security requirements.

The exact size, configuration and placement of spaces will vary to suit each building's particular characteristics.

For all projects, consideration must be given to the potential impact of densification to the building and building services. All applicable codes, regulations and standards must be adhered to.

Base Building Requirements

The starting point for any fit-up project is determined by the base building conditions. Whether the facility is Crown-owned or leased, base building conditions will always vary depending on the location, age, size, classification and other characteristics of the site. In leased space, the extent of the landlord's responsibility with respect to those conditions is as outlined in the PSPC Generic Lease Documentation Package and finalized through lease negotiations. No modifications may be made to the base building elements other than those itemized in the lease agreements or otherwise taken into account in making the original investment decision.

The *Technical Reference for Office Building Design* sets out the base building requirements for Crown owned buildings as well as forms the basis for facilities occupied by the federal government. The technical reference is the primary reference for all technical and life safety standards related to plumbing, HVAC, fire protection, electrical and telecommunication systems.

Note: All fit-up projects must be in accordance with the appropriate municipal and provincial codes and consideration must be given to the potential impact of densification on base building systems.

Information Technology (IT)

Shared Services Canada (SSC) has the mandate to provide services related to data centres, networks, email and end user information technology. SSC's clients include both mandatory and optional users. SSC, the Communications Security Establishment (CSE) and Public Safety Canada have a shared responsibility for cyber and IT security, with oversight provided by TBS.

SSC's mandate applies to providing efficient workplace solutions to meet the *Government of Canada's Workplace Fit-up Standards*, primarily in the networking and telecommunications services category. Specifically, the provision of these services may include: wired LAN, cabling and Wi-Fi services; cellular amplification services; telephony systems; and audio, web, and videoconferencing services.

Under this mandate, SSC is responsible for the design, development, delivery and ownership of network and end-user IT infrastructure and standards that align technology architecture across the Government of Canada. SSC's role and responsibilities with respect to office fit-up ensures that a common enterprise service management model is applied, ultimately providing consistent and integrated IT support services to end-users.

Special Fire Protection Standards for Client-funded Requirements/SPS

In addition to provincial or territorial code requirements, there are some standards and policies that must be followed when developing office space for Government of Canada occupants. The most common ones are listed below. You may find the specific requirements of each at the accompanying Web site locations.

1. TB Fire Protection Standard
2. Fire Commissioner of Canada—FC 311 (M)—Standard for Record Storage
3. Operations Program Directives No. 922-1-IPG-044—Door Release Hardware—Electromagnetic Locks
4. Mobile Shelving—Fire Protection Design Requirements

It is imperative that these standards and policies are considered early in the concept design stage, and as part of the review and approvals process throughout the development of the project.

A2. Approvals and Governance

A2.1 Compliance with the *Government of Canada Workplace Fit-up Standards*

The *Government of Canada Workplace Fit-up Standards* are supported by Treasury Board Secretariat and PSPC at all management levels. A compliance monitoring process is outlined in this section to ensure common sense is exercised in the application of the quality and quantity of fit-up elements and space allocation that is established as a baseline in the Standards. It is the responsibility of both PSPC, contracted service providers and client departments and agencies to work within the Standards.

Non-compliance

Client requests that would result in a fit-up of either higher or lower quantity or quality that otherwise would create non-standard office accommodation will be considered non-compliant. All variations to the Standards are subject to discussion with all project stakeholders to determine non-compliance with the Standards and obtain appropriate approval.

Common Sense and Best Value for Canadians

The *Government of Canada Workplace Fit-up Standards* are the baseline for the identification of non-compliance; however, there can never be a substitute for sound judgment and common sense. The project team must use the Standards wisely and question the justification for each non-compliant client requirement on a case-by-case basis.

An overall advantage to the taxpayer and the Crown takes precedence over benefits to a particular client and these Standards. However, minor adjustments to the approach or to the typical provisions included in the *Government of Canada Workplace Fit-up Standards* that can benefit the client without having adverse impact on the planning principles, project quality or cost, may be considered.

For example, in certain situations, coat storage may be more appropriate and useful to the client than cabinet storage in a shared equipment area, and an exchange of these fit-up elements is deemed acceptable.

Also, if a space is leased “as is”, but the hard walled spaces are not sized according to the Standard (larger or smaller) or the number exceeds the allocation, “right sizing” or demolishing the spaces may not demonstrate sound judgement or sustainability (economic or environmental). In such cases, hard walled office spaces in excess of the standard allocations could be used to accommodate two or more workstations.

Similarly, non-compliance to the Standard may be required to allow for limitations in the ability to modify heritage buildings.

Note: The project team must document any decisions made and include the analysis of financial, environmental, security and other factors (including justification for audit purposes) before proceeding with implementation. (Refer to [section A2.2](#) for further information on compliance monitoring.)

The following is for the purpose of providing examples that may provide justifications for criteria listed in [section A2.5](#), however it should not be considered an exhaustive list:

Financial	Environmental	Security	Other
Short and long-term investment	Sustainability	Health and safety	Operational Requirements
Budget	Greening	Laws, Policies, etc.	Governance (Acts, Policies, Standards)
Other financial risks	Wellness (work environment, employees)	Applicable Building and Fire Codes	Schedule, Resources

Approval Authorities for Non-compliance with the *Space Allocation Standards* and the *Government of Canada Workplace Fit-up Standards*

The Accommodation Standards Committee (ASC) was established within PSPC to help ensure a disciplined, objective, and consistent approach to decision-making, monitoring and reporting on the implementation of the *Government of Canada Workplace Fit-up Standards*.

The ASC evaluates requests from departments and agencies for exemptions from the *Space Allocation Standards* and the *Government of Canada Workplace Fit-up Standards*, and prepares a recommendation to the ADM, Real Property Services (RPS) or sub-delegated authority. Regional project teams evaluate, assess and authorize both project specific non-compliance and special purpose space requests while the ASC has an oversight role on all decisions taken at the project level. The ADM, RPS (or sub-delegated authority) has the final authority should an agreement not be reached throughout the project specific process. For program specific requirements and SPS with a department-wide application, the ASC has a review and recommendation role, whereas the final approval authority rests with the ADM, RPS (or sub-delegated authority).

In client departments and agencies, it is recommended that a comparable level of authority be identified to approve the departments’ or agencies’ justified requests for non-compliance, to approve the funding, and to accept accountability for the decisions and any project delays, if applicable.

A2.2 Compliance Monitoring

It is critical that both the client department/agency and PSPC exercise due diligence in protecting the interests of the Crown and the taxpayer with regard to federal accommodation spending. All project specific non-compliance decisions, which include those reached through a common sense approach, must be reported to the Accommodation Standards Committee (ASC) for monitoring and reporting. The committee’s role is to ensure project teams are following a disciplined, objective, and consistent approach to decision-making on the implementation of the *Government of Canada Workplace Fit-up Standards*. (Refer to table in [section A2.3](#).)

Fit-up Projects

The delivery of fit-up projects follows the PSPC National Project Management System (NPMS). Each phase of the process and each deliverable represents an opportunity to validate any decision that would result in additional space outside of the *Space Allocation Standards* and/or a fit-up of either higher or lower quantity or quality, that otherwise would create non-standard office accommodation. The project team determines the project-specific compliance or non-compliance with the *Space Allocation Standards* and the *Government of Canada Workplace Fit-up Standards*, completes the required analysis with the client stakeholder, documents the decision and reports to the ASC (identified in the detailed process in [section A2.3](#)).

The completion of the Client Accommodations Requirements Questionnaire (CARQ) at the Project Identification Stage, and the subsequent development of the Functional Program, where required, and Investment Analysis Report (IAR) will put to the forefront any potential non-compliance with both Standards. Compliance continues to be monitored at each subsequent phase of the project. Where non-compliance occurs, the Compliance Monitoring Form is to be completed. The form serves to record the nature of the request, the costs, the recommendation of the project team, and the decision of the ADM RPS (or sub-delegated authority), on approval. (Refer to [section A2.3](#) for the approval process and [section A2.7](#) for a copy of the Compliance Monitoring Form.)

The client department is responsible for submitting the justification or business case for each non-compliance request, providing the funding, and accepting accountability for any delays in the project incurred by the approval process. (Refer to [section A2.4](#) for details on the submission requirements for requests for non-compliance approval.)

Note: Any non-compliance request resulting in expansion space to the space envelope would be client funded and in accordance with the Funding Framework and to the PSPC/Treasury Board Quasi-Statutory submission process.

As described in [section A2.1: Compliance with the *Government of Canada Workplace Fit-up Standards*](#), in some cases, the project team may determine that minor adjustments to the Standards provide the optimum solution, represent common sense and best value to the Crown, and would not require approval of the ADM, RPS (or sub-delegated authority). Regarding the “common sense” decision approach, it implies that there is a minimal cost and/or non-financial impact in terms of the context of the whole project, the request or situation is not precedent setting and represents best interest and best value to the Crown (financial and non-financial factors). Such decisions and their justification must be documented on the Compliance Monitoring Form, copied to the ASC Secretariat and the form must be completed and attached to every project file.

Tenant Service Projects

Tenant service projects must be similarly monitored for compliance with the *Space Allocation Standards* and the *Government of Canada Workplace Fit-up Standards*. The Compliance Monitoring Form must be completed for every project, copied to the ASC secretariat and approved in accordance with the project-specific approval process outlined in [section A2.3](#). In the case that tenant service projects are not typically lead by a PSPC project leader, the responsibility to complete the compliance monitoring would fall to the PSPC project manager, project facilities manager or contracted service provider that is leading the project.

Note: Reimbursing departments are subject to the same compliance monitoring process as non-reimbursing departments. As well, contracted services are monitored through performance-based contracts and their work is subject to audit to assure compliance with the *Government of Canada Workplace Fit-up Standards*.

A2.3 Process for Approval of Non-compliance

Project-specific: Non-compliance and Special Purpose Space Requests

The following table describes the project specific decision making and approval process for any space or elements that would result in a fit-up of either higher or lower quantity or quality, that otherwise would create non-standard office accommodation as a result of fit-up or tenant service projects. The project team determines the project-specific compliance or non-compliance with the *Space Allocation Standards* and the *Government of Canada Workplace Fit-up Standards*, copies the ASC and documents the decision on the project file. The ASC's role and responsibility in this process is one of oversight and to ensure national consistency.

Timelines for preparation and submission of non-compliance requests are initially submitted to the project team and will **vary** depending on the complexity of the request and project requirements. The department or agency is the lead in preparing and submitting documentation and is responsible for project delays.

Project Specific: For the non-compliance and Special Purpose Space approval process, typically a decision would be reached in Level 1, however the following table describes the escalation process when all stakeholders are unable to reach a decision or alternate solution:

Level 1

Step 1: Client

- .1 Client submits space or fit-up requirement(s) that differ from both Standards to the project team leader:
 - Project team for Fit-up, Tenant Service projects and major renovations may have some or all of the following members involved: Project Leader, Client Accommodation Service Advisor/Accommodation Manager, Project Manager, Design Manager, Professional and Technical Operations and Services, Asset and Facilities Management, AFD Service Provider, Consultant, etc.
 - The responsibilities outlined in the following process would fall to the PSPC project manager, project facilities manager or contracted service provider that is leading the project where a PSPC project leader is not part of the project team.

Step 2: Program Team

- .1 Project team reviews the requirement(s) that differ from the Standards.
- .2 Project team confirms that the requirement is Special Purpose Space or non-compliant additional support space or non-compliant space or fit-up elements with the *Space Allocation Standards* and/or *Government of Canada Workplace Fit-up Standards* and/or and determines whether to support it based on the evaluation criteria in [section A2.5](#) and common sense and best value for the Crown.
- .3 Project team advises client on:
 - Whether or not the solution for the requirement is supported; and
 - The impact on project delivery including associated schedule and financial risks while an agreed approach and/or solution is determined.

Step 3: Client

- .1 If client decides not to pursue the request, project continues with compliant requirements.
- .2 If client decides to pursue the non-compliant requirement, an evaluation and approval process begins.

Level 2**Step 4: Project Leader**

- .1 Project Leader completes the Compliance Monitoring Form, listing and costing each non-compliant item.
- .2 Project Leader provides client with a copy of the form and requests that it be completed with their submission as detailed in [section A2.4](#) for approval by the project team.

Step 5: Client

- .1 Client completes and signs the Compliance Monitoring Form and prepares their rationale including the justification for the request, and acknowledges accountability for funding of additional costs and for associated project delays. (**Note:** This must be signed off at a level of financial authority within the client department and sent to the Project Leader.)

Step 6: PSPC/Project Leader

- .1 Project Leader evaluates the rationale and supporting documentation with the project team. Discussion and decision reached by the project team is recorded and documented on the project file. Copy of decision complete with the Compliance Monitoring Form and justification is sent to the ASC Secretariat, Workplace Solutions.
- .2 If client is not in agreement with the project team's decision or proposed alternate solution, the request escalates to Level 3.

Level 3**Step 7: PSPC**

- .1 The Director Level of the PSPC sector delivering the project and Client Account Executive and Regional Client Service Director are presented with the project team's evaluation and recommended decision along with the client's rationale and supporting justification.
- .2 The Director, Regional Client Service Director and Client Account Executive reviews the project team's recommendation and evaluates the rationale and supporting documentation. Discussion and decision reached by the Director and Account Executive is shared with the project team and recorded and documented on the project file. Copy of decision with the Compliance Monitoring Form and justification is sent to the ASC secretariat, Workplace Solutions for monitoring purposes.

Step 8: Client

- .1 If the client is not in agreement with the project team's decision or proposed alternate solution, the request escalates to Level 4.

Level 4**Step 9: PSPC**

- .1 The Director General Level of the PSPC Sector or Region delivering the project are presented with the project team's evaluation by the Client Account Executive and recommended decision along with the client's rationale and supporting justification.
- .2 The Director General reviews the Director and Account Executive's recommendation. Discussion and decision reached by the Director General and Account Executive is shared with the project team and recorded and documented on the project file. Copy of the decision with the Compliance Monitoring Form and justification is sent to the ASC Secretariat, Workplace Solutions for monitoring purposes.

Step 10: Client

- .1 If the client is not in agreement with the project team's decision or proposed alternate solution, the request escalates to Level 5.

Level 5

Step 11: Client

- .1 Client's Assistant Deputy Minister (ADM), writes to the ADM, RPS (or sub-delegated authority) and includes the client's rationale and supporting justification. The ASC Secretariat, Workplace Solutions provides the ADM, RPS (or sub-delegated authority) background information on decisions and recommendation from Level 4.
- .2 ADM, RPS reviews recommendation and tasks the ASC with performing a review of all information and providing a recommendation.

Step 12: PSPC

- .1 ASC reviews recommendation from Level 4 of the process, the client's ADM letter and rationale and provides the ADM, RPS (or sub-delegated authority) with a recommendation.
- .2 ADM, RPS (or sub-delegated authority) reviews the ASC's recommendation and draft decision letter.

Step 13: PSPC

- .1 ADM, RPS (or sub-delegated authority) finalizes decision letter and sends to client department, advising of decision and the rationale on which it is based. Copy of response is recorded with project team and the ASC Secretariat, Workplace Solutions.

Step 14: Client

- .1 Client department or agency accepts decision, and project proceeds.

Process for Approval of Program-Specific Requirements and Special Purpose Space with Department-wide Application

The following table describes the national process for managing requests for exemptions to the *Government of Canada Workplace Fit-up Standards* and/or *Space Allocation Standards* and for approval of program-specific requirements and special purpose space that is intended for application on a department-wide basis. The ASC determines compliance or non-compliance with the *Space Allocation Standards* and the *GCworkplace Fit-up Standard*, and provides a recommendation to the ADM, RPS (or sub-delegated authority) for approval. The ASC's role and responsibility in this process is to ensure national consistency between other government departments and agencies as well as consider proposed alternate solutions for future versions of the Standards.

Timelines for preparation and submission of requests are initially discussed with the PSPC Account Executive. Draft submissions to the ASC Secretariat will vary depending on the complexity of the request and project requirements. The department or agency is the lead in preparing and submitting documentation and accepts accountabilities for project delays.

Development of Draft Stage

Step 1: Client

- .1 Client department or agency informs PSPC Account Executive in writing of their intent to develop special purpose space or general administrative accommodation standards for program-specific requirements.

Step 2: PSPC

- .1 PSPC Account Executive informs Director General, Workplace Solutions and ASC Secretariat.

Step 3: PSPC

- .1 PSPC Account Executive arranges a meeting with client department or agency and members of initial review team to discuss process, options and impacts on funding. If client decides to pursue the non-compliant requirement, the approval process begins.

Draft Review Stage

Step 4: PSPC

- .1 Client department provides Account Executive with draft non-compliance submission and Account Executive forwards it to the Director General, Workplace Solutions and ASC Secretariat.
- .2 ASC Secretariat reviews the submission, identifies issues and may recommends the review be expanded to ASC members should the size and complexity of the submission warrant.

Step 5: PSPC

- .1 Where the review is expanded this may include comments from the following areas:
 - Managers, Workplace Solutions
 - Regional representatives
 - Professional and Technical Operational Services representatives
 - Furniture technical authority representatives
 - Space envelope National analysts

Step 6: PSPC

- .1 ASC Secretariat provides draft with consolidated comments to Manager, Policies, Workplace Solutions.
- .2 ASC Secretariat then forwards to the Account Executive.
- .3 Account Executive forwards comments to Client Department.

Step 7: Client

- .1 Client department revises submission to reflect PSPC's comments.

Final Review and Approval Stage

Step 8: Client/PSPC

- .1 Client department or agency submits revised request for approval of Program-specific requirements and/or SPS with a department-wide application to their Account Executive.
- .2 Account Executive forwards request to the Director General, Workplace Solutions and to the ASC Secretariat.

Step 9: PSPC

- .1 ASC Secretariat sends a copy of submission to ASC members.
- .2 ASC reviews submission and makes final recommendation on approval.
- .3 ASC Secretariat prepares draft letter of response with recommendation on approval to Director General, Workplace Solutions.

Step 10: PSPC

- .1 Director General, Workplace Solutions, finalizes letter and sends it to the client department or agency. Letter is copied to the Account Executive.
- .2 ASC Secretariat, communicates decision to ASC members and all who provided comments and ensures regions have access to the submission and decision letter through GCDocs.

Step 11: Client and PSPC

- .1 Client department or agency accepts decision and communicates the decision internally as appropriate.

A2.4 Submission Requirements

PSPC

Project-specific

PSPC Project Leaders are to send an e-mail to the ASC Secretariat informing the committee of a department's or agency's non-compliance request, the project team's decision and whether or not it has been accepted by the client stakeholder. E-mails are to include the following information:

1. Description of non-compliance request;
2. Summary of relevant facts and issues;
3. Impact of request on accommodation savings and space reduction targets;
4. Position of the project team;
5. Copy of the completed Compliance Monitoring Form; and
6. Completed [Special Purpose Space \(SPS\) Assessment Tool](#) when applicable.

Client Department or Agency

Project Specific Requests

Departments and agencies must submit their requests for any space or elements that would result in a fit-up of either higher or lower quantity or quality, that otherwise would create non-standard office accommodation for approval by the project team. The project team determines the project-specific compliance or non-compliance with the *Space Allocation Standards* and the *Government of Canada Workplace Fit-up Standards*, copies the ASC and documents the decision on the project file. The ASC's role and responsibility for this type of request is one of oversight of the decisions reached and to ensure national consistency.

Dependent on the size and complexity of the request for additional space and/or fit-up elements' non-conformity, the client stakeholder's rationale must be accompanied by a justification, client department senior management level approval, confirmation of funding, and acceptance of accountability for any project delays incurred in the approval process. The related funding accountability determined will cover all direct and indirect costs related to the implementation of the non-compliant item or service, including management and design services, project delays, and ongoing operational and maintenance costs.

Program-Specific Requirements and SPS with Department-Wide Application Requests

Departments and agencies must submit their requests for program specific requirements that are in addition to the *Space Allocation Standards* and vary in quantity and quality from the fit-up elements detailed in the *Government of Canada Workplace Fit-up Standards* as well as special purpose space with a department-wide application to the ADM, RPS (or sub-delegated authority), for approval.

Requests for program specific requirements and SPS with department-wide application must be accompanied by a justification, client department senior management level approval, confirmation of funding, and acceptance of accountability for any project delays incurred in the approval process. The funding will cover all direct and indirect costs related to the implementation of the non-compliant fit-up element or service, including management and design services, project delays, and ongoing operational and maintenance costs.

Submissions are to be prepared in consultation with PSPC, and must include all information described in [section A2.8: Business Case Template](#).

Justification Based on Security

When the recommended option is based on security, the justification submitted by the client department or agency must include:

- Reference to text from a Threat and Risk Assessment (TRA), Security Design Brief or Security Site Brief that specifically supports the request. If these documents are not available, they must be developed before the business case is submitted;
- In the case of project-specific requests, if there is sufficient reason for not developing any of the above-noted documents, a letter from the Departmental Security Officer must be provided and include, where appropriate:
 - a statement of the security requirement necessitating the non-compliant fit-up;
 - an explanation as to why separate secure zoning is not an acceptable alternative;
 - the security classification of the information being handled i.e., Confidential, Secret, Top Secret, Protected A, B, or C; and
 - legal liabilities.

Information on Government of Canada security requirements including approaches to physical security and the selection and design of facilities can be found in the *Treasury Board Operational Security Standard on Physical Security*.

A2.5 Criteria for Evaluating Requests for Non-compliance

The Accommodation Standards Committee uses the following criteria to evaluate requests for exemption to the *Government of Canada Workplace Fit-up Standards*. They evaluate the common sense decisions taken at the project level with the same criteria and weigh against the supporting justifications that include analysis of financial, environmental, security and other factors.

1. Is the request a program requirement?
2. Is the request due to a health and safety issue?
3. Have alternate solutions been appropriately considered?
4. Is the request in the best economic interest of the Crown and taxpayer?
5. Does the request demonstrate sound judgment and common sense?
6. Does the request have an impact on the achievement of accommodation savings?

A2.6 Non-compliance Trends and Reporting

The Accommodation Standards Committee monitors project-specific decisions and program specific requirements and SPS with a department-wide application approvals and consider the results and evident trends in developing future versions of the *Government of Canada Workplace Fit-up Standards*.

For monitoring purposes, the ASC Secretariat reviews project specific project team decisions and determines topics for review and discussion by the ASC to ensure national consistency.

A2.7 Compliance Monitoring Form

Date:

Project Summary	
Project Title:	
Building Name/Address:	
Client Department:	
Building Cost Centre:	Project Number:
Project Size (um ²):	Project Type/Qualifier:
Office Space Type:	Project Cost Estimate:
Date Space Required:	Source of Funding:
Term of Occupancy:	Project Status:

PSPC Project Team
Project Leader:
Accommodation Manager:
Project Manager/Officer:
Design Manager:
Property and Facilities Manager:

Non-compliance Requirement
Description of decision of project team and rationale:

Non-compliant request	Cost Estimate	Supported by Project Team (Yes/No)	ADM RPB (or sub-delegated authority) (Yes/No)
Total Cost Estimate:			

Contacts	
PSPC Project Leader Name and Title:	Phone/Fax Number:
Client Name and Title:	Phone/Fax Number:

A2.8 Business Case Template

Cover Page

[Name of department or agency]

Business case

For

[Project-specific non-compliant fit-up requirements or program-specific accommodation requirements]

[Title]

Submitted by:

[Name, title, section and branch]

Submitted to:

Assistant Deputy Minister (or sub-delegated authority),
Real Property Services,
Public Services and Procurement Canada

Date: [day/month/year]

Business Case

General Instructions: It is important that the business case be clear, concise and complete. Include only relevant information and avoid duplication. A maximum of 3 pages per item being requested, not including appendices, should be sufficient for most submissions.

Purpose

Provide a brief statement on the purpose of the business case (i.e., the non-compliant item(s) or special purpose space with a department-wide application for which approval is being requested).

Background/Context

Provide background information as it relates to the request. Normally, this section requires two to three paragraphs only and may include, for example:

- a) Mandate of the department or agency and/or the specific group or program to which the request applies;
- b) Strategic considerations, e.g., broader government objectives;
- c) If the request is project-specific, a brief description of the project and work completed to date. Include, as an appendix, the completed *Government of Canada Workplace Fit-up Standards* Compliance Monitoring Form; and/or
- d) If the request is program-specific, a list of locations to which the request applies including address, quantity, size, total area (usable m²) and population per location/region/nationally.

Request(s) for Non-compliant Fit-up

For each non-compliant fit-up item being requested, provide the following information.

Non-compliant fit-up item

Issue:

Describe the main issue(s) or problem(s) driving the request and any impact(s) on the department's or agency's operations.

Options Analysis:

Provide an analysis of all options considered for addressing the issue(s). (NB: The *Government of Canada Workplace Fit-up Standards* specified requirement must be considered as one of the options.) For each option, include the following:

- a) Brief description of the option;
- b) Gap analysis;
 - i) Gap between the option and:
 - ➔ The *Government of Canada Workplace Fit-up Standards* (elements and allocations); and
 - ➔ The *Space Allocation Standards* (usable m²); and

- ii) Impact of the gap on costs in terms of:
 - ➔ Fit-up;
 - ➔ Rent; and
 - ➔ On-going operation and maintenance.

Short term and, where appropriate, long term impacts must be considered. Details are to be provided in the appendix, as required.

Note: Include template, as appropriate.

- c) Benefits and risks in relation to, for example:
 - i) Operational requirements and/or program delivery;
 - ii) Government objectives and priorities;
 - iii) Security;
 - iv) Health and safety;
 - v) Sustainability;
 - vi) Project delivery and schedule; and
 - vii) Other.

Recommendation and Justification:

Provide a clear statement of the solution being recommended for approval and the basis for the justification.

- a) When the recommendation is based on legislation, Treasury Board policies or approvals, reports or studies, the justification must include specific reference to the relevant text within the document. The document, or excerpts from it, must be included as an appendix, where appropriate.

Funding

Include the following statement(s) to confirm the department's or agency's accountability for associated costs:

- a) For non-compliant fit-up requests: “[Client department or agency] is responsible for the cost of all items associated with this non-compliance request that exceed the approved space envelope, and *Government of Canada Workplace Fit-up Standards*, including rent, fit-up and related on-going operation and maintenance.”
- b) For special purpose space requests: “[Client department or agency] is responsible for the cost of all items associated with this special purpose space request that exceed the approved space envelope, as well as items that are not included as part of the *Government of Canada Workplace Fit-up Standards* “bundle of goods” for general purpose office space, including rent, fit-up and related ongoing operation and maintenance.”

Appendices

- a) Compliance Monitoring Form;
- b) Other documents as appropriate, for example:
 - i) Detailed gap analysis;
 - ii) Legislation, TB policies; TB minutes; reports, studies;
 - iii) Floor plans;
 - iv) Threat and Risk Assessment, Security Design Brief, Security Site Brief, or letter from the Departmental Security Officer;
 - v) Organization charts;
 - vi) Functional program; and/or
 - vii) Draft program-specific standards (for program-specific requests only).

A3. Funding Accountabilities of PSPC and Client Departments

A3.1 Funding Accountabilities by Occupancy Instrument Type

Funding accountabilities for fit-up projects are shared between PSPC and client departments and agencies in accordance with the Treasury Board approved funding framework for PSPC's real property portfolio and related services.

The following tables are to be used as a reference guide and identify PSPC and client department funding accountabilities, based on the occupancy instrument type, whether for non-reimbursing or reimbursing space, including expansion control framework (ECF) space. As well, the table identifies the funding mechanisms and its application depending on whether a project is implemented in a Crown-owned or leased facility.

Non-reimbursing Occupancy Instruments (OIs)

Inventory Impact	Project Description	Fit-up Elements (see Fit-up Standards A3.2)	Funding Department	Funding Mechanism*
During Term of OI	Tenant Services: Alterations to Existing Accommodation	Base Building	Client	SSA ¹
		Standard Fit-up		
		Other ⁶		
	Cyclical Maintenance: Repair or Replacement ⁷	Base Building	PSPC	BMP ^{2,3}
		Standard Fit-up	Client	
		Other ⁶		
	Space Optimization	Base Building	PSPC ⁵	BMP ³
		Standard Fit-up	Client	
		Other ⁶		
Same Location at OI and/or Lease Renewal	Tenant Services: Alterations to Existing Accommodation	Base Building	Client	SSA ¹
		Standard Fit-up		
		Other ⁶		
	Cyclical Maintenance: Repair or Replacement ⁷	Base Building	PSPC	BMP ^{2,3}
		Standard Fit-up	Client	
		Other ⁶		
	Refit New occupant	Base Building	PSPC	BMP ³
		Standard Fit-up	Client	
		Other ⁶		
	Space Optimization Same occupant	Base Building	PSPC ⁵	BMP ³
		Standard Fit-up	Client	
		Other ⁶		

Non-reimbursing Occupancy Instruments (OIs) (continued)

Inventory Impact	Project Description	Fit-up Elements (see Fit-up Standards A3.2)	Funding Department	Funding Mechanism*
New Location at OI and/or Lease Renewal (expansion or replacement)	Fit-up for Initial Occupancy or Refit for a New Occupant in Existing Inventory	Base Building	PSPC	BMP ³
		Standard Fit-up		
		Other ⁶	Client	SSA
Major Renovations by PSPC	Fit-up of Swing Space for Initial Occupancy or for Reuse	Base Building	PSPC	BMP ³
		Standard Fit-up		
		Other ⁶	PSPC	SSA
	Fit-up of Long Term Space for Reuse (i.e., move back to original location)	Base Building	PSPC	BMP ³
		Standard Fit-up		
		Other ⁶	Client	SSA
Forced Move by PSPC	Fit-up for Initial Occupancy or Refit for a New Occupant in Existing Inventory	Base Building	PSPC	BMP ^{3,4}
		Standard Fit-up		
		Other ⁶		

1. Tenant service projects may be identified at any stage of occupancy, and must support departmental programs, PSPC and government policy objectives, PSPC Portfolio Management Strategy and comply with the *Space Allocation Standards* and the *Government of Canada Workplace Fit-up Standards*, including the funding accountabilities outlined within this section. All tenant service requests affecting base building elements (e.g., mechanical and electrical systems, plumbing, etc.) must be approved by the building owner or representative.
2. PSPC assumes the costs of dismantling/storage/re-assembly/relocation of PSPC-funded telecommunication equipment, computer monitors at workpoints and standard furniture, as required to implement cyclical maintenance (e.g., for carpet replacement). Client departments fund dismantling, moving and reassembly of computers and specialized equipment/furnishings as required.
3. For leased facilities, base building elements are funded by the landlord as negotiated in the lease contract.
4. PSPC will replace like-for-like conditional on compliance with the *Government of Canada Workplace Fit-up Standards*.
5. Subject to PSPC funding availability.
6. The term 'other' typically refers to the following client costs: Special Purpose Space (SPS) costs beyond the PSPC bundle of goods for general purpose office space, additional security and IT requirements, additional furniture and equipment.
7. Clients would remain responsible for maintenance and replacement costs of the fit-up elements that PSPC is paying upon initial fit-up/cyclical re-fit.

*Alternate funding mechanisms may be used for projects such as a Purchase Order (PO), Local Purchase Order (LPO), Work Authorization (WA) or equivalent.

Reimbursing and Expansion Control Framework (ECF) Occupancy Instruments (OIs)

Inventory Impact	Project Description	Fit-up Elements (see Fit-up Standards A3.2)	Funding Department	Funding Mechanism*
During Term of OI	Tenant Services: Alterations to Existing Accommodation	Base Building	Client	SSA ¹
		Standard Fit-up		
		Other ⁵		
	Cyclical Maintenance: Repair or Replacement	Base Building	PSPC	BMP ^{2,3}
		Standard Fit-up	Client	SSA
		Other ⁵		
	Space Optimization	Base Building	Client	SSA
		Standard Fit-up		
		Other ⁵		
Same Location at OI and/or Lease Renewal	Tenant Services: Alterations to Existing Accommodation	Base Building	Client	SSA ¹
		Standard Fit-up		
		Other ⁵		
	Cyclical Maintenance: Repair or Replacement	Base Building	PSPC	BMP ^{2,3}
		Standard Fit-up	Client	SSA
		Other ⁵		
	Refit New occupant	Base Building	PSPC	BMP ³
		Standard Fit-up	Client	SSA
		Other ⁵		
	Space Optimization Same occupant	Base Building	Client	SSA
		Standard Fit-up		
		Other ⁵		
New Location at OI and/or Lease Renewal (expansion or replacement)	Fit-up for Initial Occupancy or Refit for a New Occupant in Existing Inventory	Base Building	PSPC	BMP ³
		Standard Fit-up	Client	SSA
		Other ⁵		
Major Renovations by PSPC	Fit-up of Swing Space for Initial Occupancy or for Reuse	Base Building	PSPC	BMP ³
		Standard Fit-up		
		Other ⁵		
	Fit-up of Long Term Space for Reuse (i.e., move back to original location)	Base Building	PSPC	BMP ³
		Standard Fit-up	Client	SSA
		Other ⁵		
Forced Move by PSPC	Fit-up for Initial Occupancy or Refit for a New Occupant in Existing Inventory	Base Building	PSPC	BMP ^{3,4}
		Standard Fit-up		
		Other ⁵		

1. Tenant service projects may be identified at any stage of occupancy, and must support departmental programs, PSPC and government policy objectives, PSPC Portfolio Management Strategy and comply with the *Space Allocation Standards* and the *Government of Canada Workplace Fit-up Standards*, including the funding accountabilities outlined within this section. All tenant service requests affecting base building elements (e.g., mechanical and electrical systems, plumbing, etc.) must be approved by the building owner or representative.
2. PSPC assumes the costs of dismantling/storage/re-assembly/relocation of screens and standard furniture, as required to implement cyclical maintenance (e.g., for carpet replacement). Client department pays for dismantling, moving and reassembling of computers telecommunications, other specialized equipment and furnishings as required.
3. For leased facilities, base building elements are funded by the landlord as negotiated in the lease contract.
4. PSPC will replace like-for-like conditional on compliance with *Government of Canada Workplace Fit-up Standards*.
5. The term 'other' typically refers to the following client costs: Special Purpose Space (SPS) costs beyond the PSPC bundle of goods for general purpose office space, services provided by Shared Services Canada, additional security and IT requirements, additional furniture and equipment.

*Alternate funding mechanisms may be used for projects such as a Purchase Order (PO), Local Purchase Order (LPO), Work Authorization (WA) or equivalent.

A3.2 Fit-up Elements and Funding Accountabilities

The following chart identifies elements that may be part of a fit-up project. Funding accountabilities for the elements are as follows:

- **PSPC Funded elements** are funded by PSPC in both non-reimbursing and Expansion Control Framework occupancies;
- **PSPC Funded in Non-reimbursing Occupancy elements** are funded by PSPC only for a department or agency's non-reimbursing occupancy;
- **PSPC Funded in Non-reimbursing Occupancy elements** for reimbursing clients and Expansion Control Framework are funded by the client department or agency;
- **Client Funded elements**, including security requirements, are funded by the client department or agency, including all related commissioning, testing and ongoing maintenance.

Alterations to existing accommodation carried out during the term of an occupancy (e.g., tenant services), are funded by the client department.

Integrated and mobile furnishings for workpoints will be provided as specified in [section A5](#) and as per the GCworkplace Standard Furniture Typical for each workpoint type. The furnishings provided for each type of workpoint may vary according to the intended use of the workpoint and therefore not all furnishings indicated will be available in all workpoint types.

Note: PSPC may fund an optimization project during an OI or upon OI renewal within the same space if supported by an investment strategy and subject to funding availability. Standard finishes (e.g., carpet, screen fabric, painted surfaces) may be replaced, repaired or refreshed at PSPC cost if required as a result of normal wear and tear.

A. Building Site Work

Elements	PSPC Funded	PSPC Funded in Non-reimbursing Occupancy	Client Funded
(a) Site preparation, site improvements, utility tunnels, site utilities (including communication media access).	Yes		
(b) Primary identification signage (building), flagpole, and base. Additional site work and site improvements increased utility requirements, etc.	Yes		Yes ¹

1. Client cost—subject to the non-compliance approval process (see [section A2](#)).

B. Substructure

Elements	PSPC Funded	PSPC Funded in Non-reimbursing Occupancy	Client Funded
1. Foundations and basements including slab on grade Alteration to suit client requirements (e.g., addition of window wells).	Yes		Yes ¹

1. Client cost—subject to the non-compliance approval process (see [section A2](#)).

C. Shell

Elements	PSPC Funded	PSPC Funded in Non-reimbursing Occupancy	Client Funded
1. Suspended floor slabs and roof structure Alteration to suit client requirements (e.g., to increase loading capacity, add stairs).	Yes		Yes ¹
2. Exterior closure, including walls, windows, doors and roofing Alteration to suit client requirements.	Yes		Yes ¹

1. Client cost—subject to the non-compliance approval process (see [section A2](#)).

D. Interior Construction

Elements	PSPC Funded	PSPC Funded in Non-reimbursing Occupancy	Client Funded
1. Walls (STC ratings refer to wall construction)			
(a) Building core, shear and shaft walls (stairwells, utility spaces).	Yes		
(b) Demising walls, multiple-tenant floors and crossover floors—constructed to meet current Building Code requirements.	Yes		
Additional demising wall treatments to meet client security requirements (e.g., wire mesh, security grills in ductwork) and related ongoing maintenance.			Yes ²
(c) Partition walls—in addition to traditional metal or wood frame construction, reusable partition systems (e.g., movable, demountable) are acceptable within the <i>Government of Canada Workplace Fit-up Standards</i> and, as such, can be used to provide enclosed spaces and support space. These systems need to be reusable and flexible (e.g., capacity to modify one element with minimal disruption to the rest of the wall system). (See part F for furniture screens/panels)		Yes	
(i) Enclosed workspaces		Yes	
<ul style="list-style-type: none"> Slab to underside of ceiling with insulation and plenum barriers (enhanced speech privacy, approximates STC 45). 			Yes ²
<ul style="list-style-type: none"> Enclosed spaces requiring secure speech privacy, as determined by a Threat and Risk Assessment (TRA)—slab-to-slab construction with insulation, (approximates STC 52). 			Yes ²
(ii) Support spaces		Yes	
<ul style="list-style-type: none"> Storage rooms, shared equipment areas, kitchenettes and similar functions—slab to underside of ceiling with insulation (standard speech privacy approximates STC 35). 		Yes	
<ul style="list-style-type: none"> Meeting, training, focus rooms and similar functions—slab to underside of ceiling with insulation and plenum barriers (enhanced speech privacy, approximates STC 45). 		Yes	
<ul style="list-style-type: none"> Telecommunications rooms—slab to underside of ceiling with insulation and plenum barriers. 	Yes		
<ul style="list-style-type: none"> Manually operated retractable or folding partition walls to create two medium meeting rooms from one large meeting room. 		Yes	
<ul style="list-style-type: none"> Other retractable or folding partition walls (Note: The project team technical experts should ensure due diligence with regards to product selection and advise the client accordingly of the pros and cons to consider.) 			Yes ²

D. Interior Construction (continued)

Elements	PSPC Funded	PSPC Funded in Non-reimbursing Occupancy	Client Funded
(iii) Glazing treatments <ul style="list-style-type: none"> Treated sidelights and clerestory glazing (single pane) with film. 		Yes	
<ul style="list-style-type: none"> Glazing for up to 25% of demountable partitions, which may comprise up to 75% of partitions in a given fit-up, as per the GCworkplace Design. (<i>Note:</i> Glazing treatments are not recommended when speech privacy is a priority.) 		Yes	
Additional partition walls to create separate secure zones or additional partition wall treatments (e.g., wire mesh, security grills in ductwork) to meet client security requirements, and related ongoing maintenance. (<i>Note:</i> This does not include the creation of additional individual closed offices or support spaces.)			Yes ²
Other additional partition walls or special construction and related maintenance, e.g., slab-to-slab construction for meeting rooms equipped with video conference systems.			Yes ¹
2. Doors and frames			
(a) Demising wall doors (e.g., suite entry/egress door)—partially glazed with film to facilitate orientation and safe movement.	Yes		
(b) Partition wall doors including partial or full glazing and film.		Yes	
(i) Flush solid core wood doors—standard height and width 2.07 m or 2.13 m × 0.91 m (6'-8" or 7'0" × 3'-0") wood veneer or paint finish. (Transfer grills are provided on telecommunication room doors if required.)			
(ii) Wood or steel frames—natural (stain) or paint finish. (<i>Note:</i> Where security is a factor, pressed steel frames are recommended, e.g., telecommunication rooms.)		Yes	
(iii) “Vision ports” or glazing inserts in doors.		Yes	
(iv) Fire-rated doors and frames as required by code.		Yes	
(v) Sliding doors—may be acceptable where there is no additional cost. Sliding doors must meet National Building Code requirements to ensure safe egress from enclosed spaces without restricting access to exits.		Yes	
(vi) Dutch doors—to address special requirements for service counters, cashier’s offices, etc. The height of the separation between the upper and lower doors must be between 730 mm—860 mm (2'-4"–2'-8") to meet accessibility requirements.			Yes ²

D. Interior Construction (continued)

Elements	PSPC Funded	PSPC Funded in Non-reimbursing Occupancy	Client Funded
Additional door and frame types or treatments to meet client security requirements.			Yes ²
Other door and frame sizes or types or additional treatments to suit client requirements.			Yes ¹
3. Door hardware			
(a) Mortise (keyed) lock set (with two sets of reproducible keys) and lever trim (handle) on suite entry doors.		Yes	
(b) Cylinder latch or keyed lock set (with two sets of reproducible keys) and lever trim (handle) on all other room doors.		Yes	
(c) Dummy levers on closet doors.		Yes	
(d) Door closers as required by building code.		Yes	
(e) Additional hardware, as required, for durability in high traffic areas, e.g., push/pull and kick plates.		Yes	
(f) Accessibility hardware on base building doors to meet CAN/CSA B651.	Yes		
Additional accessibility (Duty to Accommodate) or security hardware and related ongoing maintenance.			Yes ²
Additional door hardware and related ongoing maintenance.			Yes ¹
4. Interior specialties			
(a) Washrooms			
(i) Core washroom fixtures, compartments, counters and dispensing accessories to meet the <i>Technical Reference for Office Building Design</i> .	Yes		
(b) Cabinetry and millwork			
(i) Counters and/or storage cabinets in kitchenettes and shared equipment areas—custom grade construction or modular units (at comparable cost). Finishes to suit application and respect criteria outlined in section A5.1 .		Yes	
(ii) Service counters and carrels in public contact spaces only (construction and finishing as above).			Yes ²
(iii) Kiosks for public contact spaces.			Yes ²
(iv) Primary reception counter.			Yes ²
(v) Coat closet—rods and shelves as allocated.		Yes	
(vi) Storage shelving, etc., (including high-density mobile systems).			Yes ²
Additional interior specialties and related ongoing maintenance (e.g., additional millwork, modifications to base building washrooms).			Yes ¹

D. Interior Construction (continued)

Elements	PSPC Funded	PSPC Funded in Non-reimbursing Occupancy	Client Funded
5. Interior finishes (see section A5)			
(a) Building core areas			
(i) Wall, floor, ceiling and base treatments to core areas, main entrance, lobbies and other base building support areas.	Yes		
(b) Office and support areas			
(i) Ceiling finishes			
• Base building standard (typically acoustic tile).	Yes		
• Bulkheads as required to suit mechanical design or other site constraints.	Yes		
(ii) Floor finishes			
• Typically carpet (rolled goods or carpet tile), resilient sheet or tile, ceramic tile or “unfinished” (sealed concrete) to suit function of space.	Yes		
• Modifications to base building floor finishes to enhance way finding and durability in major circulation paths (carpet inserts) maximum 10% of floor area unless using carpet tile.		Yes	
• Antistatic floor treatments in LAN rooms.			Yes ²
• Raised floor systems and ramps, epoxy or other special treatments to suit client requirements.			Yes ²
(iii) Wall/base finishes			
• Exterior perimeter walls and columns (to meet the <i>Technical Reference for Office Building Design</i>).	Yes		
• Partitions (paint or unfinished to suit performance requirements and substrate, limited use of wall coverings as required in high traffic areas only).		Yes	
• Wall base treatment to suit flooring.	Yes		
• Wall treatments including tackable/acoustical treatments and writable surfaces. See section A5: Finishes for details.		Yes	
Additional finishes and related ongoing maintenance.			Yes ¹

1. Client cost—subject to the non-compliance approval process (see [section A2](#)).
2. Client cost—**NOT** subject to the non-compliance approval process. Security requirements must be based on a Threat and Risk Assessment (TRA), Security Design Brief or Security Site Brief, signed off by the Departmental Security Office (DSO) and properly documented on the project file.

E. Services

Elements	PSPC Funded	PSPC Funded in Non-reimbursing Occupancy	Client Funded
1. Conveying systems			
(a) Vertical transportation, finished elevators and escalators (if existing in building).	Yes		
(b) Keyed access, additional doors, and private elevators.			Yes ¹
Additional systems or modifications and related ongoing maintenance.			Yes ¹
2. Plumbing systems			
(a) Basic building and core area services, including regular and accessible plumbing fixtures, drinking fountains, domestic water, sanitary waste and rainwater systems (does not include hard plumbed water coolers).	Yes		
(b) Stainless steel sink(s) in kitchenettes complete with hot and cold water, insulation, drain and vent piping.		Yes	
(c) Washrooms (in addition to base building washrooms) for the exclusive use of the client, including all related fixtures and services.			Yes ¹
(d) Washrooms/showers required as part of TBS approved departmental program requirement only—fixtures to match base building quality.			Yes ²
(e) Common shower facilities (TB Workplace Fitness Policy applies).			Yes ²
(f) Relocate/add drinking fountains to suit planning requirements.		Yes	
Additional systems and related ongoing maintenance.			Yes ¹
3. Heating, ventilation and air-conditioning systems			
(a) Basic building and core area systems, including fuel supply, heat generation, rejection, distribution and transfer systems, controls, testing and balancing.	Yes		
(b) Main trunk ductwork, branch ductwork, base building terminal units, controls and base building distribution.	Yes		
(c) Relocate and/or add, ductwork, terminal units (VAV boxes, fan coil units, etc.), diffusers, controls, including systems testing and balancing (testing and balancing to meet requirements of the Technical Reference for Office Building Design).		Yes	
(d) Meeting/training rooms, public service area, kitchenette and shared equipment area ventilation—add/relocate terminal units (VAV boxes, fan coil units) recirculating fans or A/C units including associated controls.		Yes	

E. Services (continued)

Elements	PSPC Funded	PSPC Funded in Non-reimbursing Occupancy	Client Funded
(e) Separate continuous 24/7 cooling in telecommunications rooms, common equipment rooms and/or distributor rooms as part of the building infrastructure to meet environmental conditions specified in TIA-569-B (for new major retrofit or new construction or new major lease buildings).	Yes		
(f) Separate continuous 24/7 cooling in dedicated telecommunications rooms and dedicated equipment rooms that house tenant equipment to meet environmental conditions specified in TIA-569-B (for new major retrofit or new construction or new major lease buildings).			Yes ¹
(g) Controls and monitoring—relocate and/or add thermostats, valves, sensors, terminal unit controller (VAV boxes, fan coil units control) control points, etc.		Yes	
Additional systems and related ongoing maintenance (e.g., additional or separate air conditioning for server or UPS rooms).			Yes ¹
4. Fire protection systems			
(a) Sprinkler, standpipe and hose systems (all areas), fire extinguishers.	Yes		
(b) Relocate/add sprinkler heads and hose systems to suit layout.		Yes	
(c) Heat detectors, smoke detectors as required by code.		Yes	
(d) Additional fire extinguishers as required by code.		Yes	
Additional fire protection systems and related ongoing maintenance.			Yes ¹
5. Electrical systems			
(a) Power			
(i) Service, distribution and emergency (life safety) Building power (including main and floor level electrical rooms).	Yes		
(ii) Relocate/add power circuits (typically one-circuit/two workstations) receptacles, conduits and raceways to suit function and layout.		Yes	
(iii) Dedicated circuits and other specific requirements in support spaces.		Yes	
(iv) UPS, “clean” power and other dedicated circuits for client operational requirements.			Yes ²
(v) Generator for client’s operational requirements and downstream distribution.			Yes ²
(vi) Enhanced accessibility measures (e.g., visual alarm systems, etc.)—Duty to Accommodate.			Yes ²

E. Services (continued)

Elements	PSPC Funded	PSPC Funded in Non-reimbursing Occupancy	Client Funded
(b) Lighting			
(i) Lighting and power distribution to core and open office areas.	Yes		
(ii) Modifications to base building fixtures (luminaires).			Yes ¹
(iii) Relocate/add base building lighting to suit function and layout.		Yes	
(iv) Lighting modifications to suit meeting room functions.		Yes	
(v) Task lighting for up to 25% of workpoints as per the GCworkplace Design.			Yes ²
(vi) Additional lighting and power for special client needs.			Yes ¹
(c) Controls and monitoring			
(i) Controls and instrumentation (e.g., computerized switching, energy monitoring and control systems).	Yes		
(ii) Modify controls and/or instrumentation to suit layout or monitoring requirements (e.g., separate switching of closed offices, meeting rooms etc. or monitoring the energy consumption of a particular function or group). The use of motion sensor lighting controls is required.		Yes	
(iii) Critical level and advanced controls for special client requirements (e.g., specialized control systems for computer room).			Yes ²
(d) Fire alarm systems			
(i) Fire alarm with smoke detectors, bells, pull stations, voice communication and annunciators.	Yes		
(ii) Relocate/add fire alarm points to suit office layout.		Yes	
(e) Sound masking systems			
(i) Sound masking system to suit office layout.		Yes	
Additional electrical systems, infrastructures and related ongoing maintenance.			Yes ¹
6. Telecommunications Systems			
(a) Spaces and pathways			
(i) Shared Entrance Room, Main or Common Equipment Room, Equipment Room and Main or Common Telecommunications' Rooms.	Yes		
(ii) In leased buildings also housing non-GC occupants, Telecommunications' Rooms as part of the building infrastructure as required.	Yes		
(iii) Dedicated Equipment Room or dedicated Telecommunications Room.			Yes ¹

E. Services (continued)

Elements	PSPC Funded	PSPC Funded in Non-reimbursing Occupancy	Client Funded
(iv) Generic backbone (also called “vertical” or “riser”), pathways (such as conduit, cable tray and sleeves) connecting Telecom Room(s) on each floor to the Equipment Room and connecting the Equipment Room to the Entrance Room and/or Common Equipment Room.	Yes		
(v) Dedicated backbone pathways requested by the client.			Yes ¹
(vi) Generic horizontal raceways (such as cable tray or conduit) from Telecom Room(s) on each floor. “J-hooks” may be used when the Crown has only a short-term interest in the space.	Yes		
(vii) Service poles for workstations and conduit in partitions for image, voice and data outlets. (<i>Note:</i> Separate poles may be required for voice and data.)		Yes	
(viii) Additional telecommunications infrastructure.			Yes ¹
(ix) Infrastructure for secret telecommunications.			Yes ²
(b) Cabling			
(i) Generic backbone cabling (vertical and to connect multiple telecommunications rooms on the same floor). <ul style="list-style-type: none"> • LAN drops provided for 20% of workpoints, individual and collaborative combined. 	Yes		
(ii) Telephony—Horizontal cabling and jacks for voice, data, image.		Yes	
(iii) Horizontal cabling and jacks for secret infrastructure.			Yes ²
(iv) Horizontal cabling and jacks for video conferencing.		Yes	
(v) Horizontal cabling and jacks for security equipment (such as Card Readers).			Yes ²
(vi) Wi-Fi cabling infrastructure equipment, design, procurement and installation.		Yes	
(c) Telecommunication equipment			
(i) Telecommunication equipment such as rooftop dishes, satellite or microwave and antennas.			Yes ²
(ii) Procurement and installation of Wi-Fi transmission devices and accessories (e.g., access points, routers, amplifiers, signal boosters, etc.)		Yes	
(iii) Maintenance and ongoing costs of the Wi-Fi infrastructure.			Yes ²
(iv) Procurement and installation of a cellphone amplification system as required.		Yes	

E. Services (continued)

Elements	PSPC Funded	PSPC Funded in Non-reimbursing Occupancy	Client Funded
(v) Maintenance of cellphone amplification systems and ongoing costs of associated devices.			Yes ²
(vi) Additional telecommunications systems, infrastructures, elements and associated maintenance.			Yes ¹
(vii) Secret infrastructure equipment, design, procurement and installation.			Yes ²
(viii) Video conferencing equipment, design, procurement and installation for all collaborative enclosed workpoints, workpoints with 40" or larger monitors and medium and large meeting rooms.		Yes	
(ix) Maintenance and ongoing costs associated with videoconferencing equipment, infrastructure and services.			Yes ²
(x) Intra-building LAN equipment.		Yes	
(xi) WAN connectivity equipment (including Accelerators and Shapers).		Yes	
7. Security (a) Base building security (lockable exterior entrances, perimeter and vehicle controls if applicable, and main level entry control).	Yes		
Additional security systems including infrastructure and related ongoing maintenance.			Yes ²

1. Client cost—subject to the non-compliance approval process (see [section A2](#)).
2. Client cost—**NOT** subject to the non-compliance approval process. Security requirements must be based on a Threat and Risk Assessment (TRA), Security Design Brief or Security Site Brief, signed off by the Departmental Security Office (DSO) and properly documented on the project file.

F. Furnishings and Equipment

Elements	PSPC Funded	PSPC Funded in Non-reimbursing Occupancy	Client Funded
1. Furnishings and Equipment			
(a) Window coverings			
(i) Coverings for exterior windows (to base building specification).	Yes		
(ii) Security film to exterior windows.			Yes ²
(iii) Additional treatments to exterior windows.			Yes ¹
(iv) Treatments to interior glazing (e.g., blinds and drapes) other than film and as noted in part D.1 (c) (iii) .			Yes ¹
(b) Furniture and equipment			
(i) Panels or screens including demountable complete with service poles and/or base feed furniture systems (mid-range quality element system, non-acoustic class with power or data capability) as per design standard outlined in the GCworkplace Technical Reference Manual.		Yes	
(ii) Integrated and mobile furnishings for workpoints as per GCworkplace Standard Furniture Typical for each workpoint type including horizontal elements (work surfaces, tables, storage pedestals), shared and personal storage solutions, monitor arms and monitors, chairs, panel or screen accessories, acoustic panels. See section A5: Finishes for additional details.		Yes	
(iii) Telephone equipment (including cellular devices and their associated ongoing costs), computers, photocopiers, fax machines, etc.			Yes ²
(iv) Wireless presentation technology including large monitors in medium and large meeting rooms and workpoints with monitors larger than 40" white board wall treatments, wireless screen-sharing equipment, etc. (including installation). See section A5: Finishes .		Yes	
(v) Kitchen equipment and furnishings including refrigerators, microwave ovens and recycling centres.		Yes	
(c) Signage and accessories			
(i) Common use signs including the main (lobby area) directory, fire exiting routes, etc.	Yes		
(ii) Operational signage including directional and location signs, informational signs, etc.		Yes	
(iii) Plants, planters and related ongoing maintenance.			Yes ²
(iv) Artwork.			Yes ²

1. Client cost—subject to the non-compliance approval process (see [section A2](#)).
2. Client cost—**NOT** subject to the non-compliance approval process. Security requirements must be based on a Threat and Risk Assessment (TRA), Security Design Brief or Security Site Brief, signed off by the Departmental Security Office (DSO) and properly documented on the project file.

A4. Planning and Design

Office Space

Space is allocated in accordance with the *Space Allocation Standards* and is based on the number of full-time equivalent (FTE) employees in the client's workplace. The design of the workplace is based on the direction set out in the *GCworkplace Design Guide*.

The *GCworkplace Design Guide* has been developed as the companion document to the *Government of Canada Workplace Fit-up Standards* and is mandatory for all planning and design of general-purpose office space.

A5. Finishes

A5.1 Finishes

The typical range of finish materials used in an office environment will achieve a variety of design concepts. Standard materials are of a midrange quality and are selected to attain sustainable design goals and provide best value for money based on a ten-year life-cycle costing analysis.

The GCworkplace Technical Reference Manual provides specifications for application of finishes and millwork in open office areas and at each workpoint. All finishes (for other items than Base Building) are provided in accordance with this document.

All standard furniture and furnishings, included in the bundle of goods, are outlined in the GCworkplace Standard Furniture Typicals document. This document provides standard typical configurations for all workpoints.

Equipment and monitor provisions are also outlined in the GCworkplace Technical Reference Manual within the GCworkplace Design Roadmap.

All of the above referenced documents may be accessed via the [GCworkplace Resources Page](#) on GCpedia.

A6. Costing

Please note that this section is currently being revised in light of the updated funding accountabilities for accommodation projects. While the guidance contained in this section remains valid, PSPC employees may consult the [Cost Planning Workbook\(s\)](#) for current up to date guidance on developing cost estimates for project approval. Once approved, the latest fit-up rates will be added to this section, until then this section is considered under development. For more information, PSPC Real Property Services employees can contact their regional costing COE, other government department clients can communicate with the PSPC project representative.

A6.1 Fit-up Rates (Under Development)

The fit-up rates are provided for:

- General administrative offices;
- Ministerial and Deputy Head accommodation;
- Quasi-judicial office space; and
- Call/contact centre space.

Rates are provided in usable square metres (um²) and rentable square metres (rm²).

The rates are established from a detailed analysis of fit-up costs and are updated each time there is a change in the type or amount, or pricing of the fit-up elements as applicable. They are based on planning examples and current market conditions in major centres across the country and will provide an average costing basis from which the specific context and conditions of the project will need to be added in order to develop a final cost estimate for planning purposes (indicative). The provision of fit-up elements indicated in [section A3.2](#) may be limited in terms of quality and quantity based on how PSPC is funded to provide them, which is linked to the calculation of the fit-up rate, and provided in support of the GCworkplace Design.

The rates are to be used to determine indicative estimates for fit-up of general administrative and public contact office space where more specific costing data is not available. Please note, however, that for general administrative, public contact as well as quasi-judicial office space, PSPC will fund standard fit-up elements for general-purpose office space as detailed in [section A3.2: Fit-up Elements and Funding Accountabilities](#) within the *Government of Canada Workplace Fit-up Standards*. All fit-up elements that exceed the standards must be funded by the client department.

The rates for general administrative offices are scaled according to three ranges of space size, and are provided for major urban centres (locations) across the country. Regions may adjust these costs for locations not identified in the tables, based on knowledge of local construction costs and market conditions.

The rate for Ministerial and Deputy Head accommodation is provided for the National Capital Area (NCA). It has been established as a *maximum limit* for determining PSPC's funding accountability for the fit-up of office suites for Ministers in departmental headquarters and for Deputy Heads.

- For fit-ups taking place in future years, rates may be escalated based on Interest Rates and Amortization Factors: <http://intranet.tpsgc-pwgsc.gc.ca/finance/gest-man/taux-rates-eng.html>. Other departments, please contact your own Finance Division to obtain this information.
- Estimates do not include post contract contingencies, GST/HST.
- Estimated demolition costs of existing fit-up or removal of unwanted assets is not included in these rates.
- The average rentable space rate is estimated by dividing the usable space rate by a 1.13 conversion factor.
- Rates do not include client costs such as Special Purpose Space (SPS) costs beyond the PSPC bundle of goods for general purpose office space, services provided by Shared Services Canada, additional security requirements, furniture and equipment (see [section A3.2 F1](#)) and additional direct and indirect costs (see [section A6.3](#)).
- The upper limits do not imply an entitlement and efforts should always be made to minimize costs.
- Elements used to forecast the fit-up rates can be found in the "PSPC Funded in Non-reimbursing Occupancy" column of [section A3.2: Fit-up Elements and Funding Accountabilities](#) within the *Government of Canada Workplace Fit-up Standards*.
- The fit-up rates only represent the basic construction costs and direct labour associated with a fit-up project. Additional direct and indirect costs funded by PSPC can be found in [section A6.3](#).
- For more information, PSPC Real Property Services employees can contact their regional costing COE, other government department clients can communicate with the PSPC project representative.

GCworkplace Fit-up Rates: (Under Development)**General Administrative Offices**

City	2019–20 Indicative Estimates					
	<1,500 m ²		>1,500 m ²		>5,000 m ²	
	\$/um ²	\$/rm ²	\$/um ²	\$/rm ²	\$/um ²	\$/rm ²
St. John's, N.L.						
Halifax, N.S.						
Montreal, Que.						
Ottawa, Ont.						
Science and Parliamentary Infrastructure Branch (Ottawa, Ont.)						
Toronto, Ont.						
Winnipeg, Man.						
Regina, Sask.						
Calgary, Alta.						
Edmonton, Alta.						
Vancouver, B.C.						
Whitehorse, Yukon						
Yellowknife, N.W.T.						
Inuvik, N.W.T.						
Iqaluit, Nunavut						

GCworkplace Fit-up Rates: (Under Development) (continued)**Ministerial and Deputy Head Accommodation**

City	2019-20 Indicative Estimates	
	\$/um ²	\$/rm ²
NCA		

Quasi-judicial Office Space

City	2019-20 Indicative Estimates	
	\$/um ²	\$/rm ²
St. John's, N.L.		
Halifax, N.S.		
Montreal, Que.		
Ottawa, Ont.		
Toronto, Ont.		
Winnipeg, Man.		
Regina, Sask.		
Calgary, Alta.		
Edmonton, Alta.		
Vancouver, B.C.		
Whitehorse, Yukon		
Yellowknife, N.W.T.		
Inuvik, N.W.T.		
Iqaluit, Nunavut		

GCworkplace Fit-up Rates: (Under Development) (continued)**Call/Contact Centres**

City	2019–20 Indicative Estimates	
	\$/um ²	\$/rm ²
St. John's, N.L.		
Halifax, N.S.		
Montreal, Que.		
Ottawa, Ont.		
Toronto, Ont.		
Winnipeg, Man.		
Regina, Sask.		
Calgary, Alta.		
Edmonton, Alta.		
Vancouver, B.C.		
Whitehorse, Yukon		
Yellowknife, N.W.T.		
Inuvik, N.W.T.		
Iqaluit, Nunavut		

Sample Fit-up Cost Estimates: Ottawa, ON (Under Development)

General Administrative Offices

Fit-up Element	<1,500 um ²	>1,500 um ²	>5,000 um ²
	\$/um ²	\$/um ²	\$/um ²
Partitions			
Doors and Frames (including hardware)			
Finishes			
Millwork and Specialties			
Plumbing			
HVAC			
Fire Protection			
Electrical			
General Requirements*			
Panels/screens (including service conduits, power receptacles and voice/data outlets)			
Fit-up Total			
WIFI infrastructure (funded by PSPC, SSC BoG)			

*General Requirements is a summary heading that includes all the fees that are directly (direct costs) related to the delivery of the construction bundle of goods elements. These include, but are not limited to, administration, profit, service trade fees and the majority of normal costs associated with having trades delivering the construction bundle of goods elements (e.g. HVAC, plumbing, electrical, etc.).

Additional Fit-up Costing items to be considered*:

- **Demountable partition** (compared to standard gypsum and steel wall stud) premiums ranges from 4% to 58% of the construction bundle of goods total depending on the configuration. PSPC's fit-up rate is based on the provision of up to 75% of demountable partitions in a GCworkplace, up to 25% of which may be glazed per the GCworkplace Design.
- **Premium for ABW concepts based upon GCWorkplace Design Guide.** Levels range from 0% to 20% of the construction bundle of goods total depending upon the level of ABW integration in the design.
- **PSPC-funded Indirect (soft) costs associated with the planning and delivery of Fit-Up Elements.** May range from 10% to 50% of the total construction costs (will depend on factors such as project delivery mechanism size, risk and complexity of project, number of consultants, etc.)
- **For additional direct and indirect costs associated with the planning and delivery of Fit-Up Elements, see [section A6.3](#).**

*The applicability and costs of the elements listed within this table are variable and are dependent on project context. It is important to note that these costs are in addition to the elements included within the Fit-up rates.

Sample Fit-up Cost Estimates: Ottawa, ON (Under Development)

(continued)

Ministerial and Deputy Head Offices

Fit-up Element	>1,500 m ²
	\$/um ²
Partitions	
Doors and Frames (including hardware)	
Finishes	
Millwork and Specialties	
Plumbing	
HVAC	
Fire Protection	
Electrical	
General Requirements*	
Panels/screens (including service conduits, power receptacles and voice/data outlets)	
Fit-up Total	
WIFI infrastructure (funded by PSPC, SSC BoG)	

*General Requirements is a summary heading that includes all the fees that are directly (direct costs) related to the delivery of the construction bundle of goods elements. These include, but are not limited to, administration, profit, service trade fees and the majority of normal costs associated with having trades delivering the construction bundle of goods elements (eg. HVAC, plumbing, electrical, etc).

Sample Fit-up Cost Estimates: Ottawa, ON (Under Development)

(continued)

Quasi-Judicial Space

Fit-up Element	>1,500 m ²
	1,030 m ²
	\$/um ²
Partitions	
Doors and Frames (including hardware)	
Finishes	
Millwork and Specialties	
Plumbing	
HVAC	
Fire Protection	
Electrical	
General Requirements*	
Panels/screens (including service conduits, power receptacles and voice/data outlets)	
Fit-up Total	
WIFI infrastructure (funded by PSPC, SSC BoG)	

*General Requirements is a summary heading that includes all the fees that are directly (direct costs) related to the delivery of the construction bundle of goods elements. These include, but are not limited to, administration, profit, service trade fees and the majority of normal costs associated with having trades delivering the construction bundle of goods elements (eg. HVAC, plumbing, electrical, etc).

Sample Fit-up Cost Estimates: Ottawa, ON (Under Development)

(continued)

Call Centre

Fit-up Element	>1,500 m ²
	1, 829 m ²
	\$/um ²
Partitions	
Doors and Frames (including hardware)	
Finishes	
Millwork and Specialties	
Plumbing	
HVAC	
Fire Protection	
Electrical	
General Requirements*	
Panels/screens (including service conduits, power receptacles and voice/data outlets)	
Fit-up Total	
WIFI infrastructure (funded by PSPC, SSC BoG)	

*General Requirements is a summary heading that includes all the fees that are directly (direct costs) related to the delivery of the construction bundle of goods elements. These include, but are not limited to, administration, profit, service trade fees and the majority of normal costs associated with having trades delivering the construction bundle of goods elements (eg. HVAC, plumbing, electrical, etc).

A6.2 Source of Funds for Non-compliant Workplace Fit-up Elements

The PSPC Real Property Services business line budget is funded to fit-up office space to meet general administrative and public contact operational requirements. Real Property Services is not resourced to cover the cost of special fit-up requirements for quasi-judicial offices, secure administrative offices and Special Purpose Space. Therefore, a source of funds must be identified to cover the difference between the cost of providing general-purpose office space and the client's special requirements. This responsibility lies with client departments and agencies; however, PSPC as a real property expert and a common service provider, can provide support in discussions with Treasury Board Secretariat.

Client departments and agencies must document any specific requirements for accommodation, including requirements for additional funding in a business case so that an appropriate funding source may be considered. PSPC can assist with:

- The confirmation of department/agency fit-up requirements;
- The identification of fit-up elements and level of service (soft costs) above standards;
- The provision of cost estimates; and
- The recognition that additional funding is required (above PSPC's funded standards) and that securing these funds is a client department/agency accountability.

Should additional funding be required, there are two potential sources of funds:

- The client department/agency's current operating budget; or
- Treasury Board (new money).

Once the source of funds is determined, several payment options can be explored. For example:

For space replacement projects

- If the source of funds is Treasury Board, the new funding can be directed to the client's budget or to PSPC's; or
- If the source of funds is the client, the client can pay by means of a Specific Service Agreement (SSA) or request an operating budget transfer to PSPC's via ARLU or Supplementary Estimates.

For expansion projects

- If the source of funds is the new approved program, the accommodation levy (13%) could be increased to a percentage that would recognize the additional costs or through a fully costed Treasury Board submission.

A6.3 Additional Direct and Indirect Costs

When project parameters are in compliance with the PSPC accommodation policies and fit-up standards, there are a number of additional direct and indirect costs considered to be part of the project delivery and funded by PSPC. As indicated in the table below, some of the standard items/activities are included in the fit-up cost limits while others must be programmed separately through Building Management Plans (BMPs) or otherwise identified at the time of the project. Costs for items/activities under the responsibility of client departments/agencies are also identified below:

A. Other Direct Costs

Other Items/Activities Inherent to Fit-up Projects	Funding Accountabilities		
	Fit-up Cost Limit	Other Project Costs	Client Cost
• Building and occupancy permits, as required.		Yes	
• Contractor's overhead and profit.	Yes		
• Commissioning—component systems and integrated systems performance testing, training, commissioning documentation including building management manual, as built, balancing, etc.	Yes	Yes	Yes
• Development of the functional program (see Glossary).	Yes		
• Dismantling, moving and reassembling computers, and other specialized equipment/furnishings or client owned items.			Yes
• Moving supplies and services for forced moves.		Yes	
• Return to initial state at end of lease or demolition in Crown-owned facilities—all standard fit-up elements.		Yes	
• Return to initial state at end of occupancy—all nonstandard items initially paid for by the client (e.g., washroom for specific tenant use).			Yes
• Security guards for after-hours work in occupied space.			Yes
• Security guard services or other expenses related to client's security needs.			Yes
• Space measurement.		Yes	
• Trade costs specifically related to the construction contract.	Yes		

B. Consultant Fees (Direct "Soft" Costs)

Other Items/Activities Inherent to Fit-up Projects	Funding Accountabilities		
	Fit-up Cost Limit	Other Project Costs	Client Cost
• Professional consulting fees for architectural, interior design, code review (if ESDC cannot provide service), mechanical, electrical and structural engineering services.		Yes	
• Fees and other costs related to additional design reviews and specialized requirements (see section A7.1: Fit-up Cost Estimate).			Yes

C. Other Fees (Direct “Soft” Costs)

Other Items/Activities Inherent to Fit-up Projects	Funding Accountabilities		
	Fit-up Cost Limit	Other Project Costs	Client Cost
• Lessor/service provider management fee for soft costs.		Yes	
• Lessor/service provider management fee for construction.		Yes	
• Lessor/service provider fee related to portion funded by the client.			Yes

D. Fees Indirect Costs

Other Items/Activities Inherent to Fit-up Projects	Funding Accountabilities		
	Fit-up Cost Limit	Other Project Costs	Client Cost
• PSPC Accommodation planning and design fee.		Yes	
• PSPC Project management fee.		Yes	
• PSPC Project leadership fee.		Yes	
• PSPC Construction supervisory fee.		Yes	
• PSPC Fee for other services, as required.		Yes	
• PSPC Fee related to portion funded by the client.			Yes
• PSPC Fee for oversight of change management		Yes	
• SSC Project management labour fee		Yes	

E. Operation and Maintenance Cost

Other Items/Activities Inherent to Fit-up Projects	Funding Accountabilities		
	Fit-up Cost Limit	Other Project Costs	Client Cost
• Standard base building, cleaning and maintenance services as described in the Occupancy Instrument.		Yes	
• Maintenance and other fees associated with client funded fit-up elements.			Yes
• Additional base building and cleaning services.			Yes

A6.4 Project Delivery Cost Controls

It is not only the fit-up project, but also the process for delivering a fit-up project, that must be controlled to help constrain costs. Extensive changes or numerous revisions during the planning and design stages risk causing delays in the project schedule as well as overruns in the budget.

In order to ensure more timely and cost effective delivery of fit-up projects, the following controls and funding accountabilities will apply:

- The “two revision rule”—The *Government of Canada Workplace Fit-up Standards* allow a maximum of two client requested revisions per deliverable during the schematic and design development stages prior to final approval. Anything over this limit is non-standard and billable to the client. (**Note:** If the two revisions are not used at one stage, there is no provision to carry the allowance over to a subsequent stage.)
- Costs related to delays in reviewing and approving project documents (drawings, specifications) are billable to the client.
- Costs related to design changes requested following the design development stage (including design, management fees and the cost of delays during the construction drawing stages and all costs resulting from changes requested during the construction or post occupancy stages) are billable to the client.
- Costs related to implementing client requested revisions to previously approved (signed off) documents are billable to the client.
- Additional design and management services generated by specialized or enhanced client requirements, including accelerated project delivery, are billable to the client.

A “client requested revision” is deemed to be a requirement or preference not previously identified, that necessitates a substantial re-examination of completed work (such as reworking of previous drawings and/or project documents), in order to find a solution that would accommodate the new requirement.

Minor adjustments to drawings that do not have substantial impact on other areas, such as relocating a door or reorienting a workstation, are not considered a “revision” relative to the “two revision rule”. Similarly, work that is deemed by the project manager to be contractually incomplete or non-compliant with the standards is not considered a client responsibility.

A7. Fit-up Cost Estimate and Tools

A7.1 Fit-up Cost Estimate

PSPC employees may consult the Cost Planning Workbook(s) for current up to date guidance on developing cost estimates for project approval. The breakdown below provides an overview of the cost categories that should be included when calculating a fit-up cost estimate.

Fit-up Element
Partitions
Doors and Frames (including hardware)
Finishes
Millwork and Specialties
Plumbing
HVAC
Fire Protection
Electrical
General Requirements ¹
Panels/screens (including service conduits, power receptacles and voice/data outlets)
IT Systems
Furnishings

1. Includes insurance, bonding, site office and supplies, site safety and security and materials handling.

Other variables that could impact fit-up costs include, but are not limited to:

- project size;
- open workstation/enclosed spaces and support space ratio;
- ceiling heights;
- specific detailing of partition assemblies;
- specific design features;
- the inclusion of “atypical” support spaces (e.g., first-aid room, primary reception area, etc.);
- existing conditions (e.g., need to relocate a fire extinguisher or fire hose cabinet, a non-uniform layout of sprinklers or air supply/returns, etc.); and
- region/municipality (e.g., the cost of developing office space is generally higher in Toronto than in Winnipeg).

A7.2 The Real Property Space Assessment and Planning App

The Real Property Space Assessment and Planning App (RP-SAPA) is used by the PSPC Real Property Services accommodation management community and Real Property and Accommodation Services within client departments as part of the real property project planning process. The Space Assessment module of the App replaces the Space Allocation Standards Calculator as it contains the ability to assess employee external mobility and its impact on a recommended space allocation limit. All results calculated on the Space Assessment App are in compliance with the *Space Allocation Standards* and the *Government of Canada Workplace Fit-Up Standards*. Use of the App is mandatory as it improves the ability to analyze options within the maximum space allocations to be applied when planning, acquiring and monitoring use of office accommodation provided by PSPC to client departments.

Access to the RP Space Assessment and Planning App is obtained after completing a 1-2 hr training session on the Space Assessment module of the App. To obtain information on upcoming training sessions, please send a request to the generic mailbox: TPSGC.Amenagement-FITUP.PWGSC@tpsgc-pwgsc.gc.ca.



Section B: Ministerial and Deputy Head Office Accommodations



B1. Introduction

B1.1 General Information

Overview

The following section has been developed to address the special fit-up requirements of Ministerial and Deputy Head office accommodation as provided by PSPC. This section follows the generic approach of the standards for general administrative office space ([section A](#)) with some exceptions, the most notable of which are size and location of enclosed offices, provision of private washrooms and dedicated support space, and modifications to wall finishes, lighting and kitchenette millwork.

Application

This section applies to accommodation for Ministers and Ministers of State and their staff in departmental headquarters offices (see *TB Guidelines for Ministers' Offices*), and for Deputy Heads and their staff, including Associate Deputy Ministers. Ministerial and Deputy Head offices are accommodated within the space envelope of the client department or agency and are **NOT** designated as special purpose space (SPS).

Please note, this section does not apply to Ministers' space on Parliament Hill, Constituency Offices, Ministers' Regional Offices (MROs) or to heads of quasi-judicial organizations.

Approvals and Governance

Approval of standards for Ministerial and Deputy Head accommodation ultimately rests with the Minister of PSPC. Ministers' departmental headquarters offices are also subject to the *TB Policies for Minister's Offices* while Deputy Heads' offices are subject to the *PSPC Accommodation Management Framework*.

The client department must provide justification for all requirements that exceed the guidelines to the satisfaction of the PSPC project team.

B2. Standards

B2.1 Fit-up Elements and Funding Accountabilities

The following chart identifies fit-up elements and funding accountabilities related to the special fit-up requirements for Ministerial and Deputy Head office suites. These elements are provided in addition to those provided for general administrative office space. The elements provided are funded as follows:

- Base building elements are funded by PSPC;
- Fit-up elements for non-reimbursing clients are funded by PSPC up to the fit-up rates for Deputy Ministerial and Ministerial Offices (see [section A6.1](#));
- Fit-up elements for reimbursing clients and Expansion Control Framework (ECF) are funded by the client department or agency;
- Other elements are funded by the client department or agency, including all related commissioning, testing and ongoing maintenance.

PSPC is responsible for initial fit-up of the space. Changes to existing offices during the term of an occupancy (e.g., during a Minister's or Minister of State's tenure or on appointment of a new Minister or Minister of State) are funded by the department or agency as a tenant service.

A. Interior Construction

Element	PSPC Funded	PSPC Funded in Non-reimbursing Occupancy	Other
1. Partition Walls			
(a) Offices for Ministers			
(i) Slab to slab construction with or without vestibule ¹ (secure speech privacy).		Yes	
(b) Offices for Deputy Heads and Associate Deputy Ministers			
(i) Slab to underside of ceiling with insulation and plenum barriers ¹ (enhanced speech privacy).		Yes	
(ii) Slab to slab construction with or without vestibule (secure speech privacy as determined by the Departmental Security Officer ¹).			Yes ¹
(c) Offices for ministerial exempt staff			
(i) Slab to underside of ceiling with insulation and plenum barriers ¹ (enhanced speech privacy).			Yes ¹
2. Door hardware			
(a) Offices and private washrooms for Ministers—mortise (keyed) lock set and lever trim (handle) on office entry and washroom doors.	Yes		
(b) Private washrooms for Deputy Heads—cylinder with thumb turn lock.		Yes	

A. Interior Construction (continued)

Element	PSPC Funded	PSPC Funded in Non-reimbursing Occupancy	Other
3. Interior specialties			
(a) Private washrooms for Ministers and Deputy Heads—three-piece washroom including built-in shower, vanity, storage and accessories as allocated in section B2.2 and as illustrated in section B4.1 .		Yes	
(b) Kitchenettes and shared equipment areas for Ministers' and Deputy Heads' suites—additional millwork as allocated in section B2.2 and illustrated in section B4.2 to accommodate dishwashers and other special requirements.		Yes	
4. Interior specialties			
(a) Wall/base finishes			
(i) Offices for Ministers, Deputy Heads and Associate Deputy Ministers—paint or unfinished to suit performance requirements and substrate, two wall surfaces may be finished in midrange quality wall covering.		Yes	
(ii) Private washrooms for Ministers and Deputy Heads—ceramic tile in shower surround and above basin, as required.		Yes	

1. Client cost—**NOT** subject to the non-compliance approval process.

B. Services

Element	PSPC Funded	PSPC Funded in Non-reimbursing Occupancy	Other
1. Plumbing systems			
(a) Private washrooms for Ministers and Deputy Heads—all related fixtures and services required for three-piece washroom with built-in shower.		Yes	
2. Heating, ventilation and air-conditioning systems			
(a) Ministerial and Deputy Head suites—modifications to base building system or independent system to meet requirement for 24/7 operations.		Yes	
3. Electrical systems			
(a) Power—Emergency power in support of 24/7 operations.			Yes ¹
(b) Lighting—Offices for Ministers, Deputy Heads and Associate Deputy Ministers—lighting modifications to suit office functions (including addition of parabolic louvers, relocation of base building lighting, addition of accent lighting). These modifications do not include the removal/upgrade of base building ceiling or lighting. (See section B4.1 for examples).		Yes	

1. Client cost—**NOT** subject to the non-compliance approval process.

B2.2 Office and Support Space Allocations

The following notes and tables describe the special office and support space allocations for Ministerial and Deputy Head suites. Where not otherwise stated below, allocations for Ministerial and Deputy Head accommodation are provided in accordance with the standards for general-purpose office space as described in [section A](#).

Office Space

Closed Offices for Ministers, Deputy Heads and Associate Deputy Ministers

See [section B4.1](#) for drawings that illustrate typical sizes and configurations of closed offices for ministers, deputy heads and Associate Deputy Ministers, including standard mechanical and electrical requirements. The following table describes the maximum size allowances for these offices.

Positions	Maximum Area (um ²)
Ministers and Ministers of State	48 ¹
Deputy heads and associate deputy heads of departments and agencies, and equivalents (e.g., Deputy Ministers, Associate Deputy Ministers)	37 ²

1. Includes 3 m² vestibule for secure speech privacy.
2. If secure speech privacy is required, add 3 m² for vestibule (client cost).

Offices may be located on perimeter walls. It is important to note, however, that acoustic control may be adversely affected by perimeter HVAC units or other building perimeter conditions.

Floor finish:	base building standard carpet
Wall finish:	paint or unfinished to suit substrate, one or two walls may be finished in mid-range quality wall covering
Lighting:	base building (may be modified and relocated to suit) and accent lighting (optional) with separate switching

Private Washrooms

See [section B4.1](#) for drawings that illustrate the typical size, configurations and millwork allowances for private washrooms. Private washrooms are provided for ministers and deputy heads only. They are not allocated to Associate Deputy Ministers. The standards include a three-piece washroom with built-in shower, vanity and storage. Provisions are as follows:

Maximum area:	9 m ²
Millwork:	1,800 linear mm (6') of counter and storage
Floor finish:	resilient sheet or ceramic tile
Wall finish:	paint or unfinished to suit substrate, ceramic tile on shower surround and above basin
Lighting:	wall mounted (sconce), recessed down lights and sealed shower light, all with separate switching

Offices for Ministerial Exempt Staff

Enclosed offices are provided for ministerial exempt staff. The maximum office size of 10 m² is applied consistently regardless of the levels of the positions. See [section B4.1](#) for drawings that illustrate typical sizes and configurations

Offices for ministerial exempt staff may be located on perimeter walls where no other option exists as a result of the high ratio of closed to open space. Standard mechanical requirements are as per those described under the typical office layout for Associate Deputy Ministers in [section B4.1](#).

Support Space

Meeting Rooms

Ministerial and Deputy Head suites are allocated a 30 m² sized meeting room each, in addition to the meeting room provided as part of the GCworkplace design for general administrative space. These meeting rooms are to be classified as special purpose space and are also typically collocated with the deputy heads' suites.

Quiet/Touchdown Rooms

Other enclosed support spaces are provided in accordance with [section A](#) for general administrative office space.

Kitchenettes

Kitchenettes are provided in both Ministerial and Deputy Head suites. The sample plan in [section B3.1](#) illustrates a typical configuration of these spaces sized to suit the population and functions they serve. The direction set out in [section A](#) for general administrative office space standards for kitchenettes, apply with the exception that millwork for Ministerial and Deputy Head kitchenettes is modified to accommodate a dishwasher. See [section B4.2](#) for a drawing that illustrates the typical millwork provisions.

Planning ratio: one 10—20 m² kitchenette per suite

Millwork: 3,000 linear mm (10') of counter and upper/lower storage per kitchenette

Equipment Areas

The direction set out in [section A](#) for general administrative office space apply with the exception that Ministerial and Deputy Ministerial suites are allocated additional space to accommodate special equipment requirements and lockable doors to provide access control.

Planning ratio: one 10—14 m² area per suite

Millwork: 2,400 linear mm (8') of counter and lower storage per area

Reception Waiting Area

A reception area with seating and display is typically located adjacent to the departmental boardroom, or as otherwise required.

Note: In instances where there are multiple Ministerial and/or Deputy Head suites on a floor, support spaces, in particular reception, meeting and kitchenette facilities, shall be shared to the greatest extent possible.

B3. Planning

B3.1 Planning and Design

Hard wall construction is significantly more extensive to provide the additional access control and speech privacy associated with Ministerial and Deputy Head offices.

However, the planning and design principles described in [section A1](#) and the *GCworkplace Design Guide* are to be applied, to the greatest extent possible, to ensure those in open workstations have access to natural light.

The following sample floor plan illustrates these factors as applied to the allocations for Ministerial and Deputy Head office and support space.

B4. Sample Detail Drawings

B4.1 Offices

Typical Office Layout with Washroom—Minister (example 1)

office—maximum 48 m² (517 ft²)/washroom—maximum 9 m² (97 ft²)

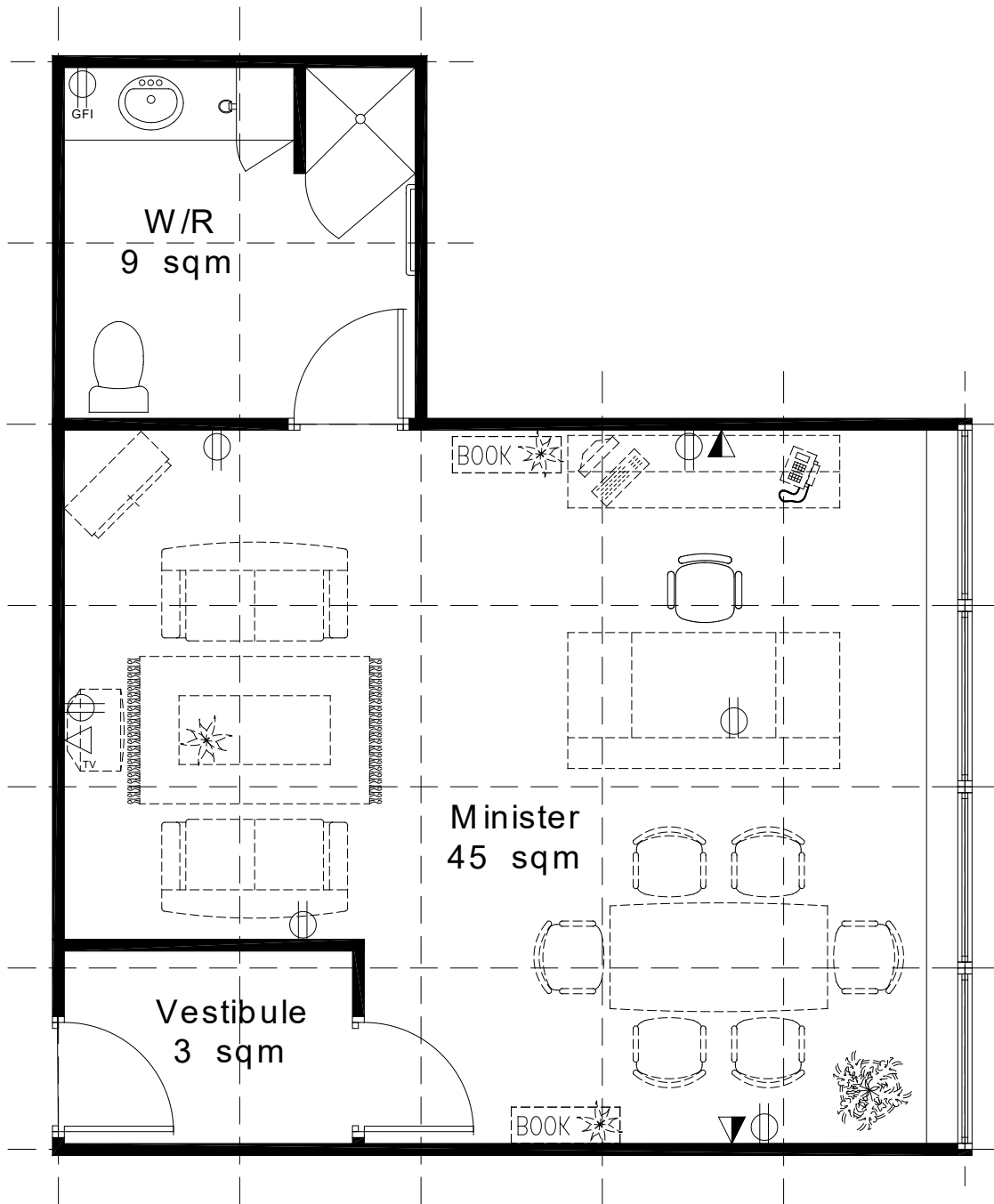

Summary

Office accommodates requirements for personal workspace, shelving, storage, soft seating and small meeting table. Furniture layouts may vary.

Standard Electrical Requirements

- 6 standard electrical duplex receptacles (2 circuits) plus GFI (ground fault interrupter) duplex receptacle in washroom
- 3 image/voice/data outlets (*Note:* client to provide actual connectors and jacks, typically RJ45 with multiple jacks.)
- separate switch/light controls as required

Standard Mechanical Requirements

Perimeter zone (*Note:* HVAC system must be capable of operating on a “24/7” basis):

- individual thermostat control c/w dedicated terminal units (VAV box, fan coil unit, air handling unit) and interlock to perimeter system
- supply and return air diffuser(s)/grille(s)
- transfer return air fan c/w on/off switch for full height partitions
- washroom exhaust c/w exhaust air grille
- water closet, sink and shower c/w sanitary, vent, hot and cold water and insulation
- hot water tank (minimum 20-25 gallons)
- noise abatement and security as required

Typical Office Layout with Washroom—Minister (example 1—reflected ceiling)

office—maximum 48 m² (517 ft²)/washroom—maximum 9 m² (97 ft²)

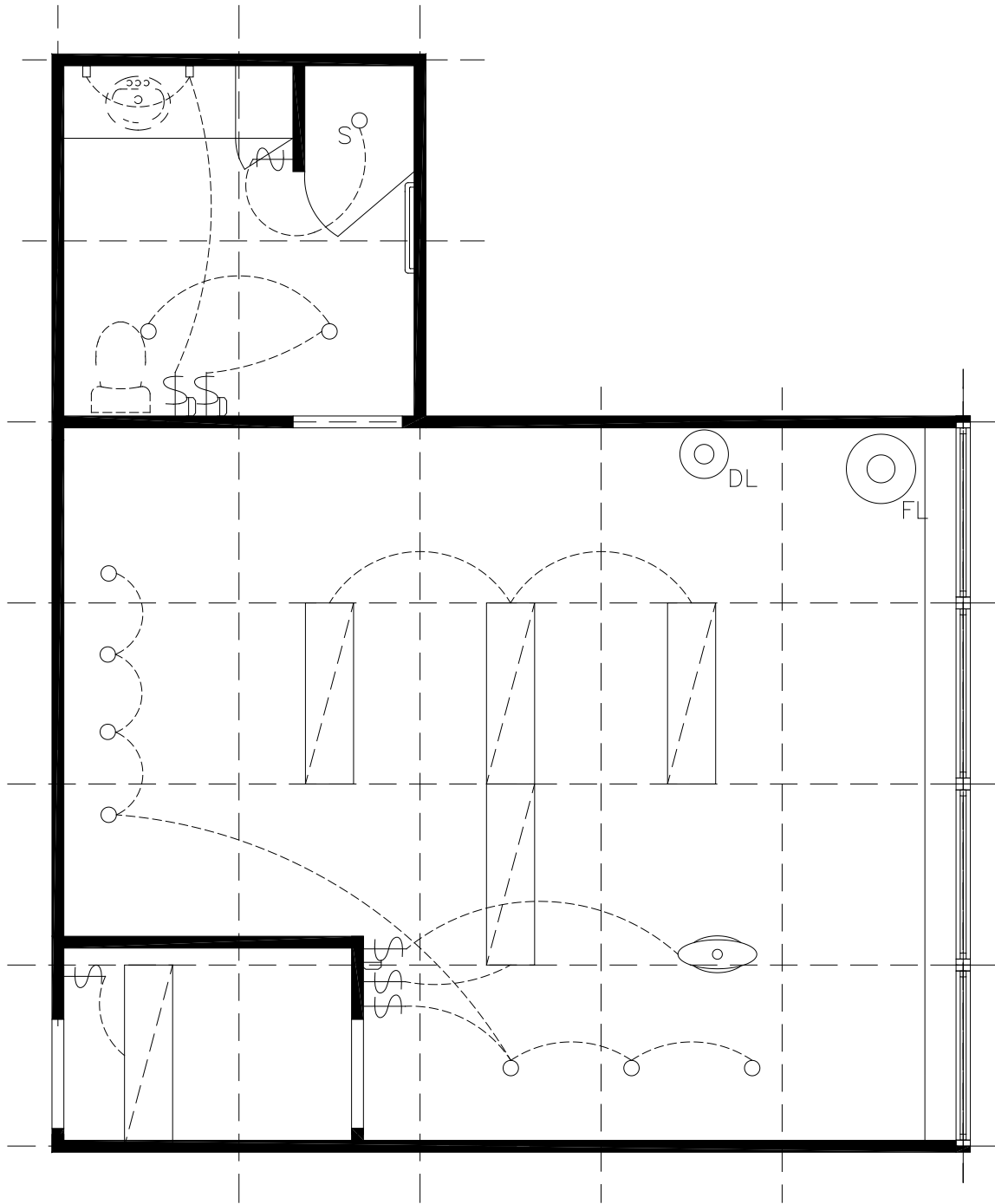

Legend

- | | | | | | | | | |
|---|---|---|---|---|---|---|---|---|
|  |  |  |  |  |  |  |  |  |
| Fluorescent light | "Pot" light (RD) | Sealed shower light | Wall sconce | Light switch | Light switch with dimmer | Floor lamp | Desk lamp | Pendant light |

Typical Office Layout with Washroom—Minister (example 2)

office—maximum 48 m² (517 ft²)/washroom—maximum 9 m² (97 ft²)

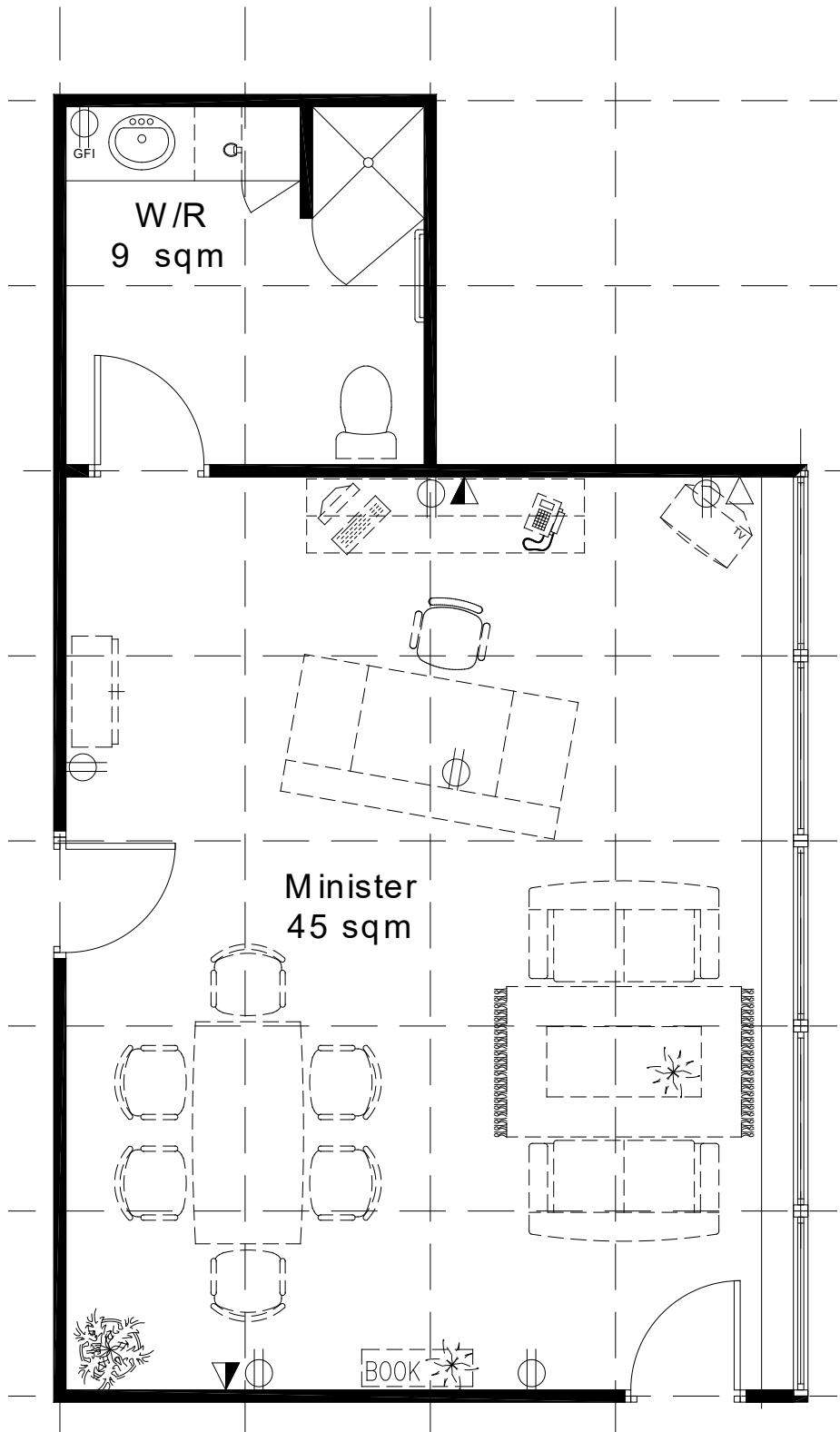

Summary

Office accommodates requirements for personal workspace, shelving, storage, soft seating and small meeting table. Furniture layouts may vary.

Standard Electrical Requirements

- 6 standard electrical duplex receptacles (2 circuits) plus GFI (ground fault interrupter) duplex receptacle in washroom
- 3 image/voice/data outlets (*Note:* client to provide actual connectors and jacks, typically RJ45 with multiple jacks.)
- separate switch/light controls as required

Standard Mechanical Requirements

Perimeter zone (*Note:* HVAC system must be capable of operating on a “24/7” basis.):

- individual thermostat control c/w dedicated terminal units (VAV box, fan coil unit, air handling unit) and interlock to perimeter system
- supply and return air diffuser(s)/grille(s)
- transfer return air fan c/w on/off switch for full height partitions
- washroom exhaust c/w exhaust air grille
- water closet, sink and shower c/w sanitary, vent, hot and cold water and insulation
- hot water tank (minimum 20–25 gallons)
- noise abatement and security as required

Typical Office Layout with Washroom—Minister (example 2—reflected ceiling)

office—maximum 48 m² (517 ft²)/washroom—maximum 9 m² (97 ft²)

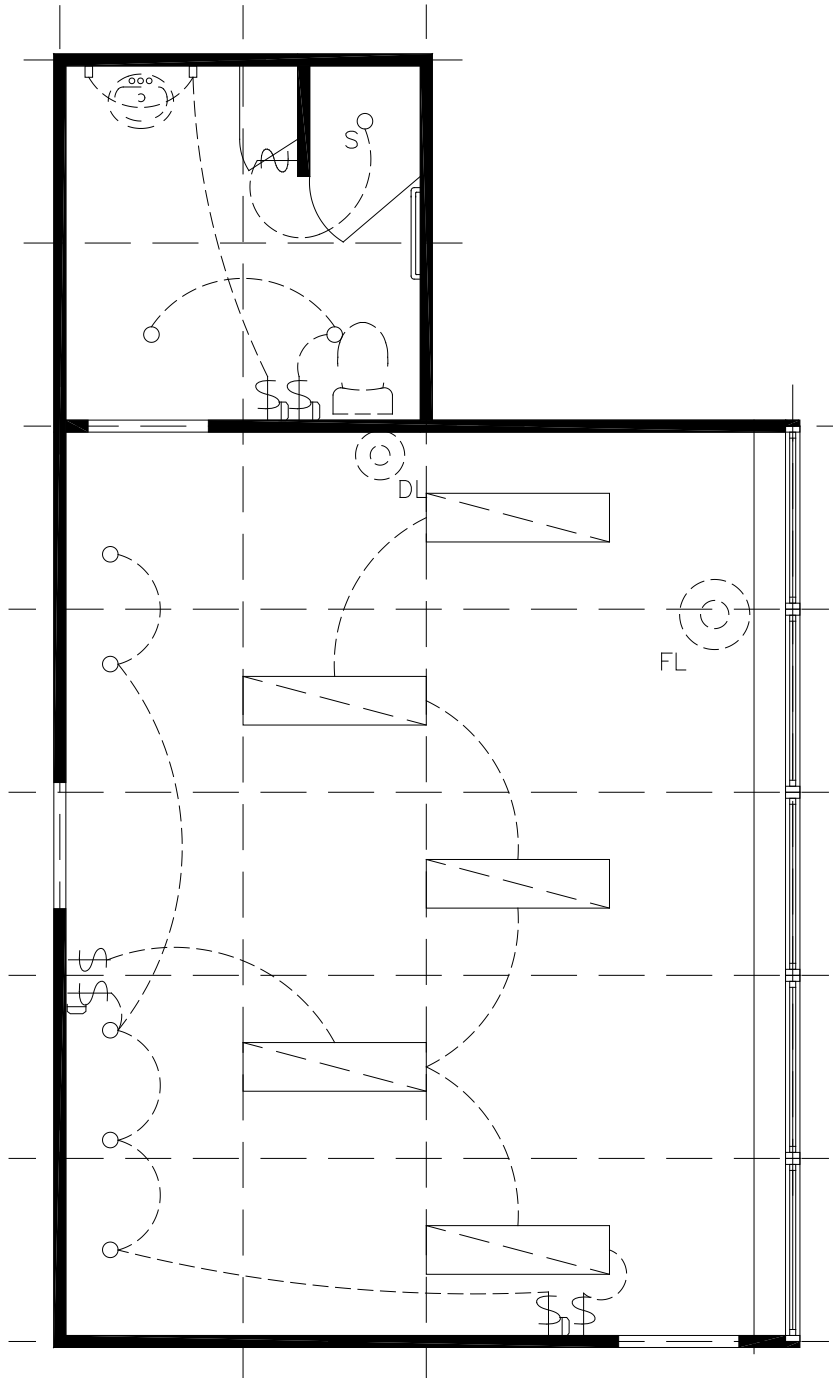

Legend

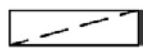

Fluorescent light



"Pot" light (RD)



Sealed shower light



Wall sconce



Light switch



Light switch with dimmer



Floor lamp



Desk lamp



Pendant light

Typical Office Layout with Washroom—Deputy Minister

office—maximum 37 m² (398 ft²)/washroom—maximum 9 m² (97 ft²)

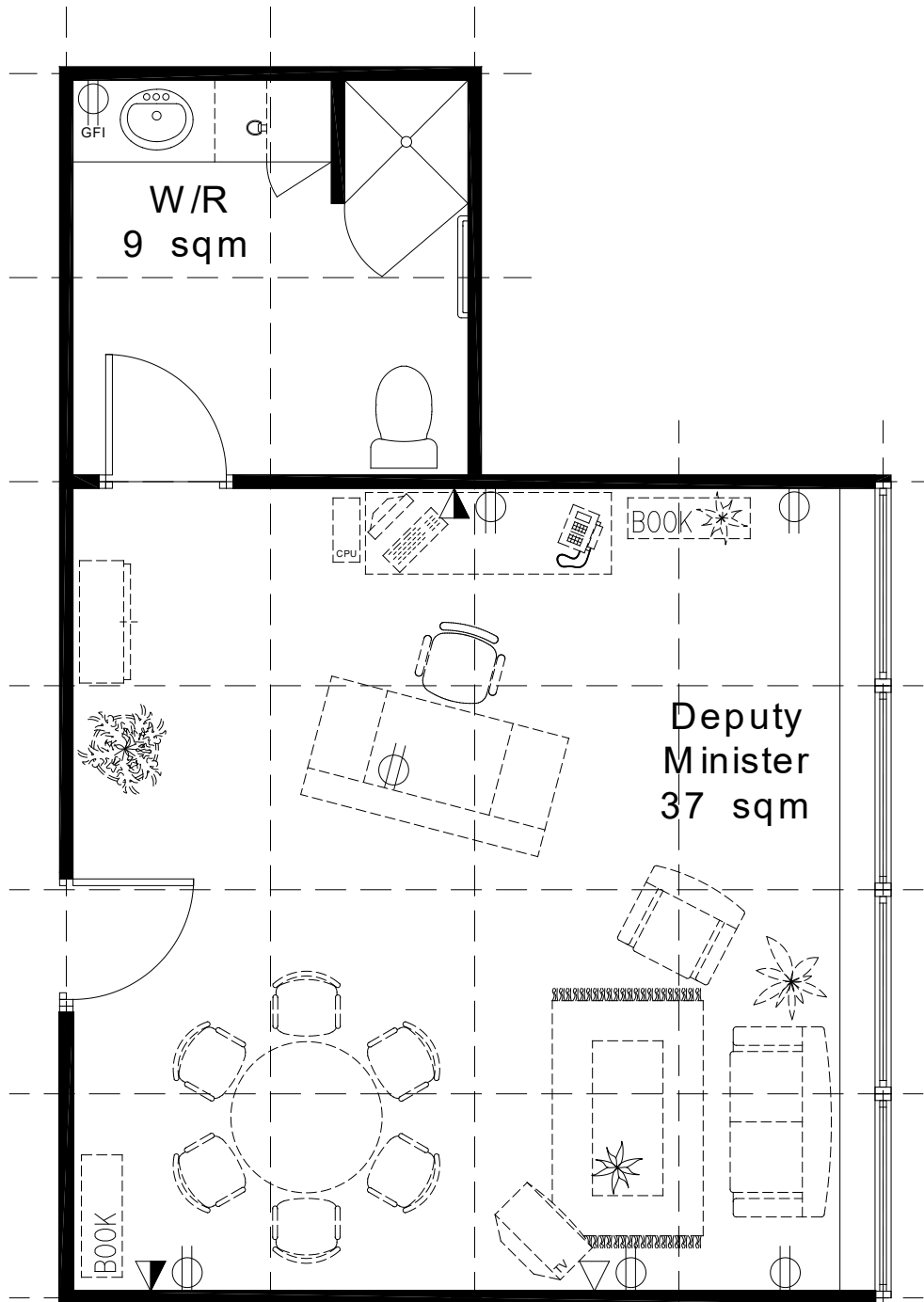

Summary

Office accommodates requirements for personal workspace, shelving, storage, soft seating and small meeting table. Furniture layouts may vary.

Standard Electrical Requirements

- 6 standard electrical duplex receptacles (2 circuits) plus GFI (ground fault interrupter) duplex receptacle in washroom
- 3 image/voice/data outlets (*Note:* client to provide actual connectors and jacks, typically RJ45 with multiple jacks.)
- separate switch/light controls as required

Standard Mechanical Requirements

Perimeter zone (*Note:* HVAC system must be capable of operating on a “24/7” basis.):

- individual thermostat control c/w dedicated terminal units (VAV box, fan coil unit, air handling unit) and interlock to perimeter system
- supply and return air diffuser(s)/grille(s)
- transfer return air fan c/w on/off switch for full height partitions
- washroom exhaust c/w exhaust air grille
- water closet, sink and shower c/w sanitary, vent, hot and cold water and insulation
- hot water tank (minimum 20–25 gallons)
- noise abatement and security as required

Typical Office Layout with Washroom—Deputy Minister (reflected ceiling)

office—maximum 37 m² (398 ft²)/washroom—maximum 9 m² (97 ft²)

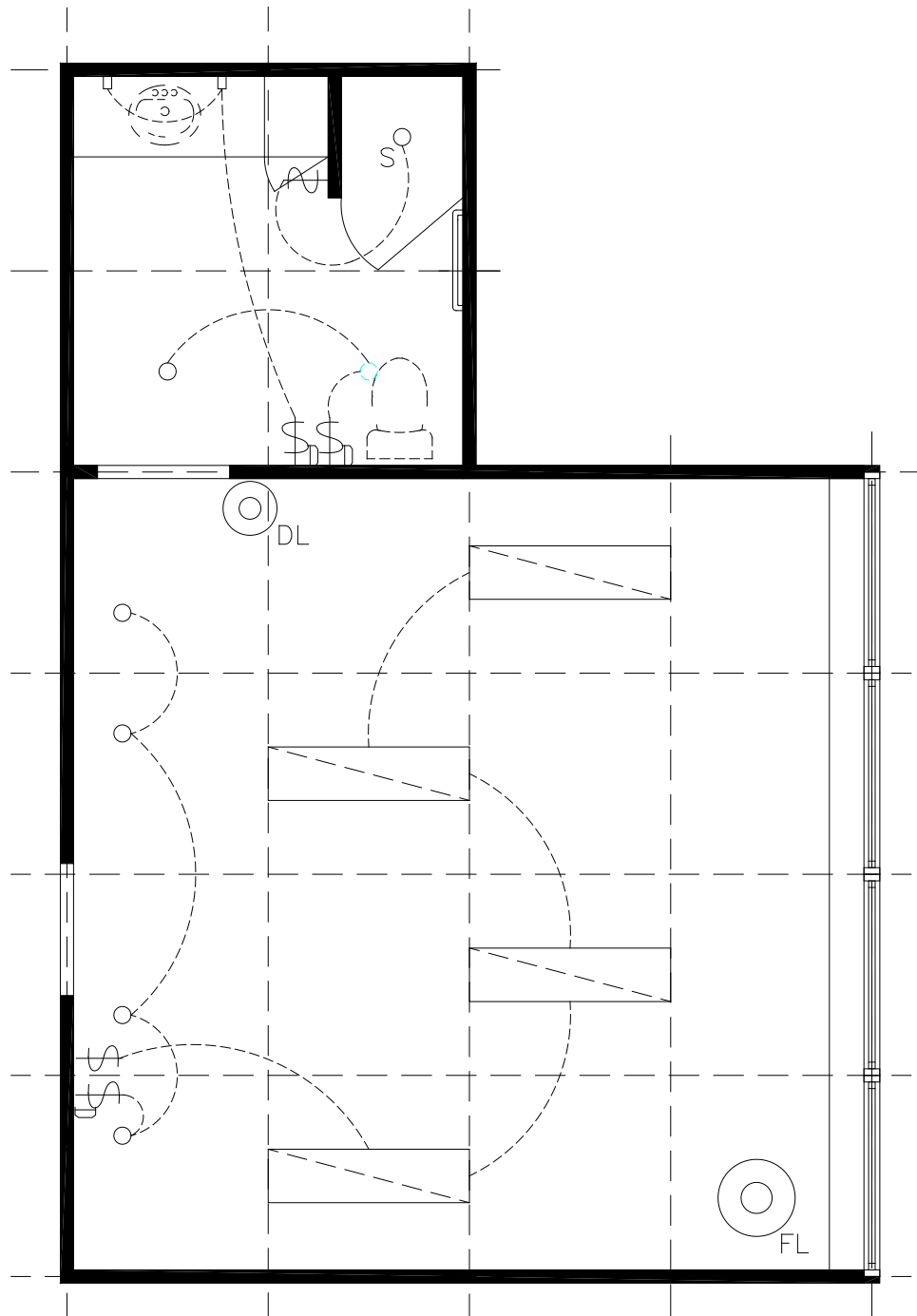

Legend

- | | | | | | | | | |
|---|---|---|---|---|---|---|---|---|
|  |  |  |  |  |  |  |  |  |
| Fluorescent light | "Pot" light (RD) | Sealed shower light | Wall sconce | Light switch | Light switch with dimmer | Floor lamp | Desk lamp | Pendant light |

Typical Office Layout—Associate Deputy Minister

office—maximum 37 m² (398 ft²)

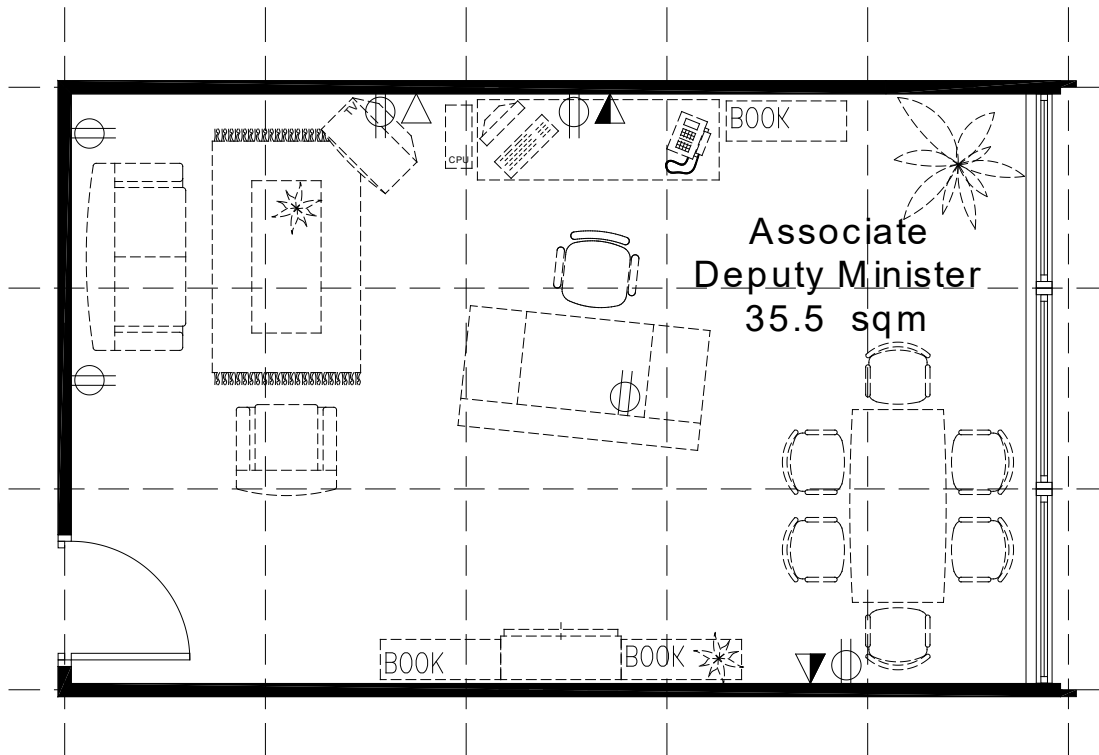

Summary

Office accommodates requirements for personal workspace, shelving, storage, soft seating and small meeting table. Furniture layouts may vary.

Standard Electrical Requirements

- 6 standard electrical duplex receptacles (2 circuits)
- 3 image/voice/data outlets (**Note:** client to provide actual connectors and jacks, typically RJ45 with multiple jacks.)
- separate switch/light controls as required

Standard Mechanical Requirements

Perimeter zone (**Note:** HVAC system must be capable of operating on a “24/7” basis.):

- individual thermostat control c/w dedicated terminal units (VAV box, fan coil unit, air handling unit) and interlock to perimeter system
- supply and return air diffuser(s)/grille(s)
- transfer return air fan c/w on/off switch for full height partitions
- noise abatement and security as required

Typical Office Layout—Associate Deputy Minister (reflected ceiling)

office—maximum 37 m² (398 ft²)

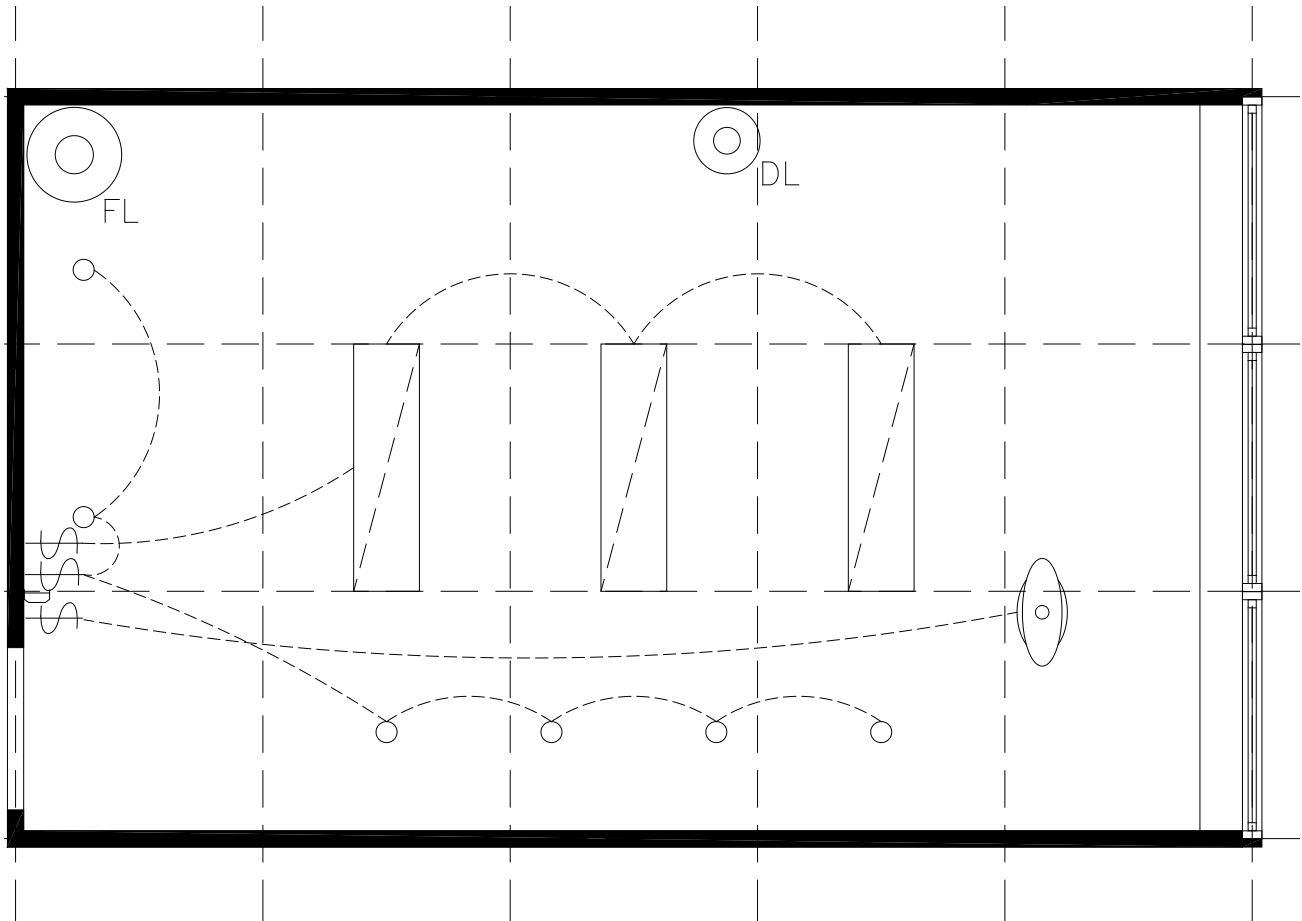

Legend

- | | | | | | | | | |
|-------------------|------------------|---------------------|-------------|--------------|--------------------------|---------------|--------------|---------------|
| | | | | | | | | |
| Fluorescent light | "Pot" light (RD) | Sealed shower light | Wall sconce | Light switch | Light switch with dimmer | FL Floor lamp | DL Desk lamp | Pendant light |

Enclosed Office for Ministerial Exempt Staff

Examples of Enclosed Office Layouts
10 m² (100 ft²)

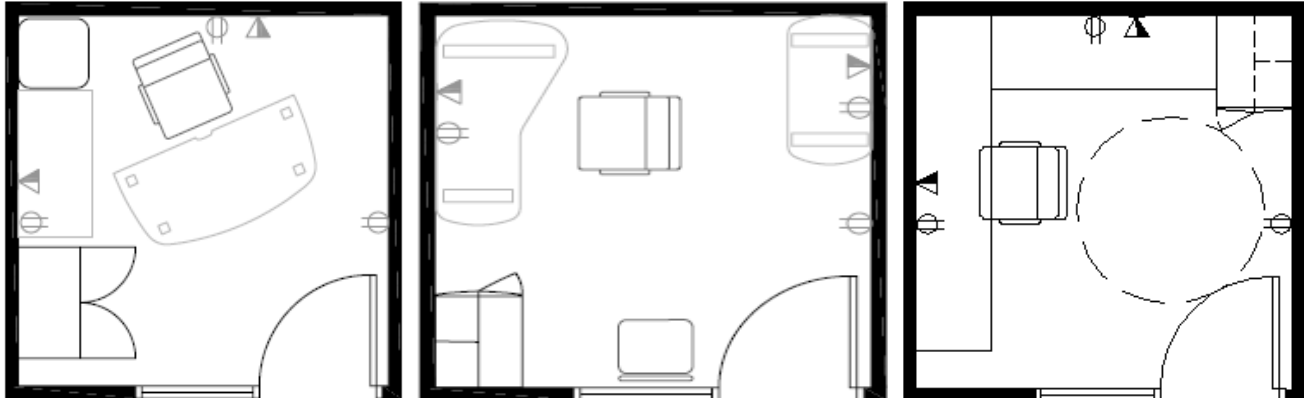

Note: This example provides for fully accessible office.

Summary

Offices accommodate average requirements for work surfaces, shelving, storage and filing. Furniture can be freestanding or hung from reusable partition systems.

Note: Furniture layouts are provided as examples and may vary.

Standard Finishes

- Floor—base building standard carpet (carpet tile or rolled goods)
- Walls—paint or unfinished to suit substrate (*Note:* partitions may be traditional construction or reusable partition systems (e.g., movable, demountable) see [section A3.2.](#))

Standard Electrical Requirements

- For 10 m² offices, 3 standard electrical duplex receptacles per office (2 circuits)
- Any circuit can be common for a maximum of four offices
- 2 image/voice/data outlets (*Note:* client to provide actual connectors and jacks, typically RJ45 with multiple jacks.)
- Base building lighting (may be relocated) with 1 separate switch/light control and dual technology motion sensor

Standard Mechanical Requirements

- See mechanical requirements set out for Typical Office Layout—Associate Deputy Minister ([section B4.1](#))

Typical Washroom Millwork (elevation)—Minister and Deputy Minister

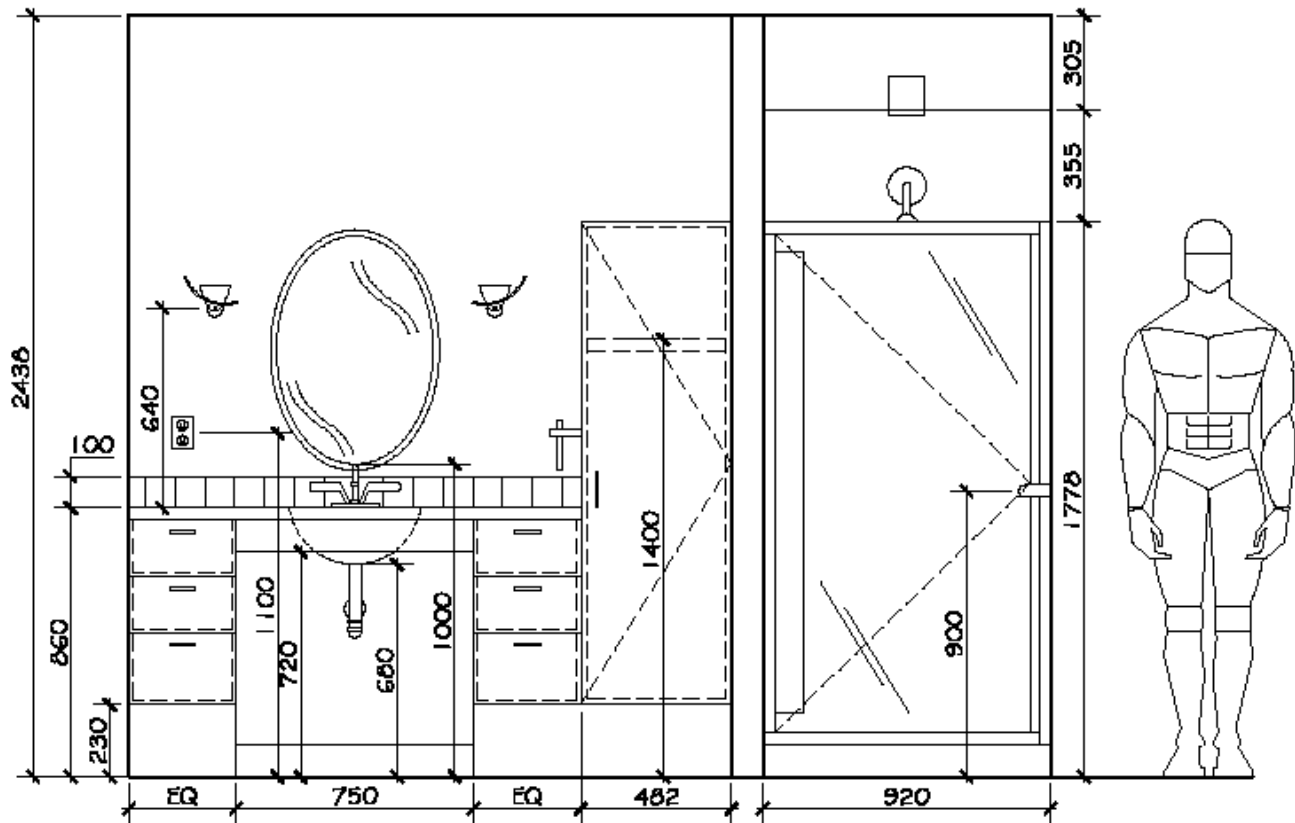

Summary

Area accommodates average requirements for washroom including built-in shower with standard glass shower door and frame assembly, hanging storage, vanity with basin and drawer storage, mirror and wall mounted lighting.

Backing to be provided in shower walls and around toilet to accommodate grab bars if required by future occupants.

Countertop and backsplash finishes to suit application and respect criteria outlined in [section A5.1](#). Mid-range quality fittings, hardware and accessories included as shown.

Standard Electrical Requirements

- 1 electrical duplex GFI (ground fault interrupter) receptacle

Meeting Room

30 m² (325 ft²)

Examples of Meeting Room Layouts

30 m² (325 ft²)

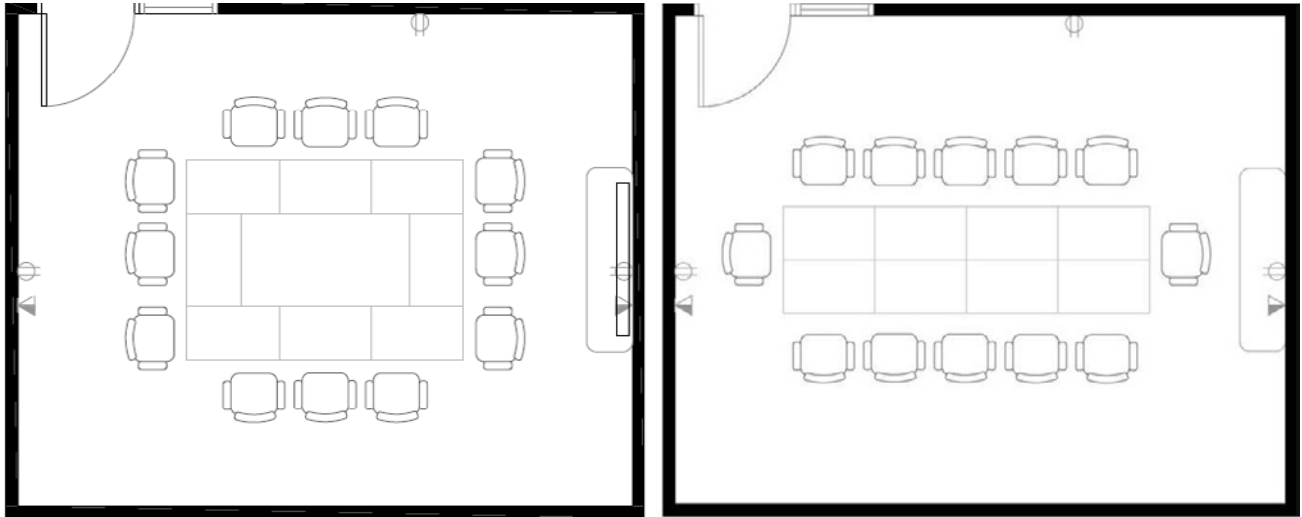

Meeting Room (reflected ceiling)

30 m² (325 ft²)

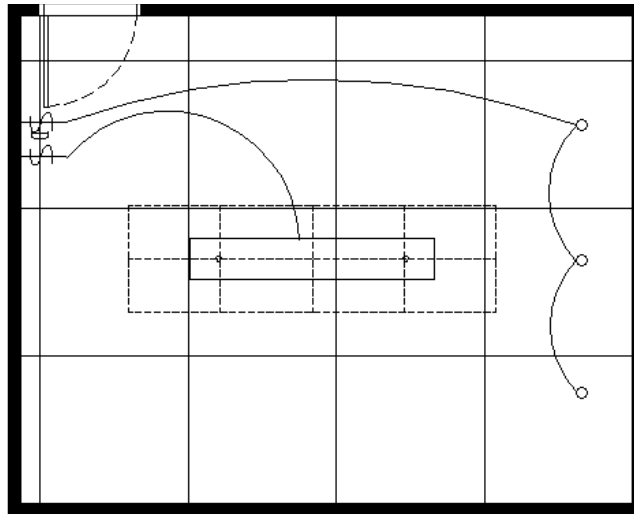

Summary

Meeting rooms accommodate a meeting table, chairs for 12 people and an audiovisual board. The room should allow for comfortable circulation space and room for a presenter to function comfortably at one end. The meeting room table should be mobile and comprised of smaller modular tables put together to maximize functionality.

Standard Finishes

- Floor—base building standard carpet (carpet tile or rolled goods)
- Walls—paint or unfinished to suit substrate

Standard Electrical Requirements

- 4 standard and 1 floor mounted electrical duplex receptacles (2 circuits) (**Note:** circuits may be common with other areas)
- 3 image/voice/data outlets; 1 only floor mounted (**Note:** client to provide actual connectors and jacks, typically RJ45 with multiple jacks.)
- Base building lighting with motion sensor
- Direct/indirect suspended luminaire(s) to suit meeting (table) function on a separate switch/light control and motion sensor
- Dimmable perimeter/accent lighting to support presentation function on a separate switch/light control and motion sensor

Standard Mechanical Requirements

- Dedicated thermostat control c/w dedicated terminal unit
- Supply and return air diffuser(s)/grille(s)
- Acoustically lined transfer duct for full height partitions (slab-to-underside-ceiling-with-plenum-barrier)
- Cooling capacity to meet demand
- Ventilation capacity to meet demand c/w CO₂ monitoring and controls
- Mechanical equipment and elements to be selected to support the room noise rating

B4.2 Support Spaces

Typical Kitchenette Millwork (elevation)—Ministerial and Deputy Ministerial Suites

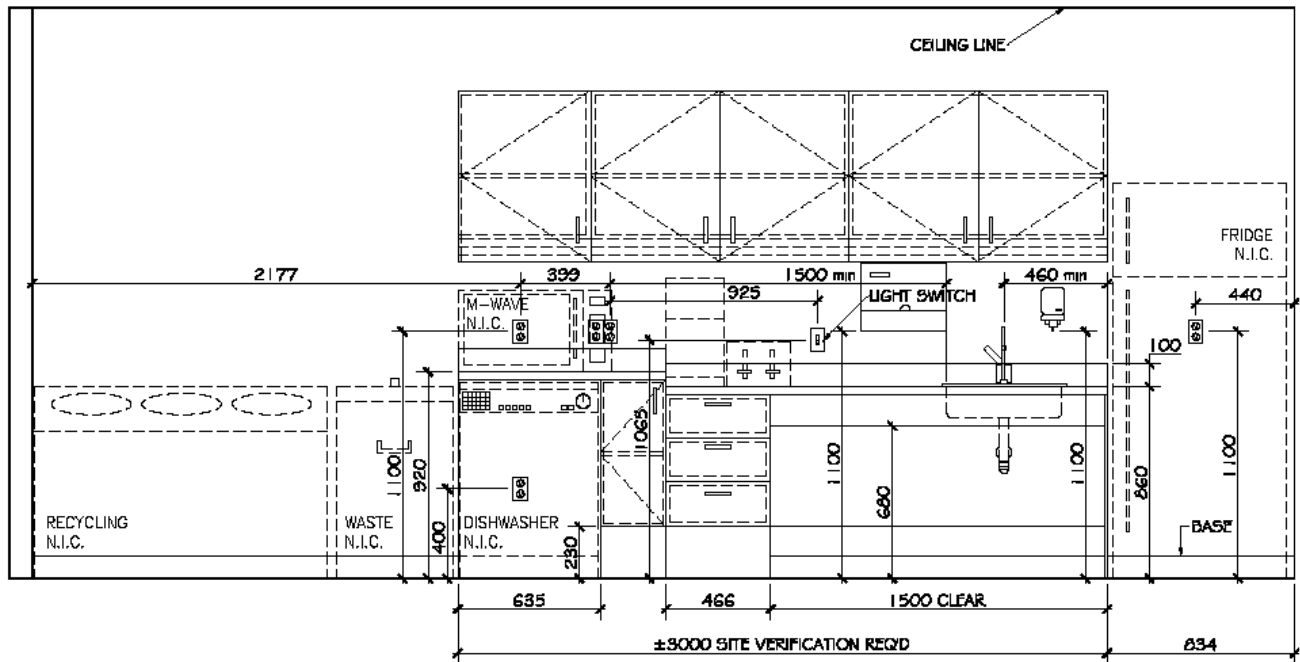

Summary

Area accommodates average storage requirements, recycling centre and trash as well as a full size fridge and countertop appliances (appliances not included). Design allows for barrier-free access to sink and counter. Paper towel and soap dispensers provided.

All finishes to suit application and respect criteria outlined in [section A5.1](#).

Standard Electrical Requirements

- 2 standard dedicated circuit duplex receptacles (microwave and fridge)
- 2 standard split circuit duplex receptacles for other countertop appliances
- 1 separate switch/light control for under cabinet lighting

Standard Mechanical Requirements

- hot water, cold water, drain and vent piping for kitchen sink
- kitchen exhaust fan c/w on/off switch (exhaust to exterior if economical and feasible)
- supply air diffuser(s) and grilles(s)
- no return air to base building system

B5. Costing

B5.1 Cost Estimates

Project managers and project officers are requested to follow the format shown in [section A7.1: Fit-up Cost Estimate](#) when preparing their cost estimates for fit-up projects. This breakdown will help to determine those types of fit up elements that are more often associated with increased costs.



Section C: Quasi-judicial Accommodations



C1. Introduction

C1.1 General Information

Overview

The following section has been developed to address the special fit-up requirements of quasi-judicial accommodation as provided by PSPC in accordance with the *Accommodation Management Framework*. This section defines a “bundle of goods” that may be provided within the existing space allocation standards for quasi-judicial functions.

Quasi-judicial accommodations are based on the general administrative office space with some additional allowances. The most notable are the provision of: closed offices for Governor in Council (GIC) appointed members; a secure (public) reception area; additional hard walled support spaces; and dual circulation, as described under [sections C2.2](#) and [C3.1](#). These additional allowances provide quasi-judicial organizations with increased flexibility to customize their space to suit their particular program requirements.

In addition to the individual workspace and support space requirements of quasi-judicial accommodations, special purpose space (SPS) may be required. Although the very nature of SPS precludes any standardization, research indicates the following types are characteristic to quasi-judicial occupancies:

- hearing rooms, with or without translation, transcription/recording rooms;
- large centralized or regional case file rooms, where long periods of on-site retention are specifically required by law.

Refer to the *Guidelines for Special Purpose Space* for criteria used to determine SPS designations.

C1.2 Application

This section applies to quasi-judicial accommodations. Quasi-judicial accommodation is used by certain departments and agencies in support of a mandate to render decisions and actions that are legally binding, but not governed by judicial organizations, such as courts.

The functions of organizations that are quasi-judicial in nature may include investigation and review of practices, protocols and individuals (victims, offenders, witnesses, members of the public) related to quasi-judicial cases, hearings, enquires and/or complaints. These functions involve face-to-face contact with members of the public and are directly related to the mandates of the organizations as well as their capacity and legislative authority to deliver judgments or binding decisions.

These organizations may also have “Headquarters” or other operations that are general administrative in nature. Therefore, each location should be carefully assessed to first confirm the function and subsequently the appropriate category of space.

Key points of clarification when managing accommodation for quasi-judicial functions include:

- No single department is completely quasi-judicial in nature. Therefore, client departments are not universally categorized as being “quasi-judicial”, but rather as departments that require some quasi-judicial accommodations to execute their federal mandate;
- Quasi-judicial accommodations are not limited to particular buildings or regions, but rather to certain occupancies;
- Quasi-judicial accommodations are a type of general-purpose office space, although, as previously noted, quasi-judicial accommodations may also have SPS requirements; and
- Quasi-judicial accommodations differ from judicial space in that judicial space is reserved for courts that render legally binding decisions with authority found in Canadian criminal and civil code (e.g., Tax Court of Canada, Federal Court, Supreme Court).

Organizations that require space for the purpose of quasi-judicial functions, may include, but are not limited to: boards, tribunals, bureaus, commissions and authorities. Some examples of departments that use quasi-judicial accommodations include: Immigration and Refugee Board, Security Intelligence Review Committee, and the National Parole Board.

C2. Standards

C2.1 Fit-up Elements and Funding Accountabilities

The following chart identifies fit-up elements and funding accountabilities related to the special fit-up requirements for quasi-judicial accommodations. All standard fit-up elements not included in this chart are provided and funded in accordance with the general administrative office space standards as described in [section A](#).

PSPC is responsible for initial fit-up of the space based on the functional and operational requirements of the end user. Changes to existing offices during the term of the occupancy are funded by the department or agency as a tenant service.

A. Interior Construction

Elements	PSPC Funded	PSPC Funded in Non-reimbursing Occupancy	Other
1. Partition Walls			
(a) Offices for GIC appointees <ul style="list-style-type: none"> slab to underside of ceiling with insulation and plenum barriers (enhanced speech privacy). (<i>Note:</i> glazing treatments may be appropriate for increased light transfer and visual access but are not recommended when speech privacy is a priority.) 			Yes ¹
(b) Support spaces <ul style="list-style-type: none"> Public reception and waiting area—slab to underside of ceiling with insulation (standard speech privacy). Interview, counsel, break-out, discovery and similar rooms, client waiting areas—slab to underside of ceiling with insulation and plenum barriers (enhanced speech privacy). Employee washrooms (supported by a TRA based Security Design Brief)—slab to slab construction. 			Yes ¹
2. Doors and frames			
(a) Employee washrooms—doors provided with transfer grills.			Yes ¹
3. Door hardware			
(a) Employee washrooms—cylinder with thumb turn lock.			Yes ¹
4. Interior specialties			
(a) Cabinetry and millwork.			Yes ¹
(i) Service counters in reception area.			Yes ¹
(ii) Counter in employee washroom.			Yes ¹

B. Services

Elements	PSPC Funded	PSPC Funded in Non-reimbursing Occupancy	Other
1. Plumbing systems (a) Employee washrooms—fixtures and accessories for two-piece washroom to match base building quality.			Yes ¹

1. Client cost—**NOT** subject to the non-compliance approval process.

C2.2 Office and Support Space Allocations

This section describes standard provisions for some typical quasi-judicial accommodation and support space allocations.

These allocations are provided in addition to the space provided for general administrative office space identified in [section A](#). Together, they must be managed within the space allocation standards for quasi-judicial accommodation. Office and support spaces beyond those that can be accommodated within the standard quasi-judicial space allocation will be considered non-compliant and subject to the Approvals and Governance process outlined in [section A2](#).

Office Space

Closed Offices for Governor in Council (GIC) Appointees

Enclosed spaces are provided for GIC appointees. The office size may range from 10 m² for EX-1 positions and up to 14 m² for EX-2 positions to suit the priorities and typical levels of members within each organization. However, one size is applied consistently within each organization to allow for long-term flexibility as appointments change. Enclosed spaces are to be located on the interior where building conditions allow.

Part-time appointees must share offices, wherever possible—typically at a 3:1 or 2:1 ratio, as appropriate.

Support Space

In addition to the common support spaces outlined in [section A](#) and the *GCworkplace Design Guide* quasi-judicial operations typically require spaces to support their public-contact activities. It is expected that the type, quantity, size, configuration and placement of these spaces will vary with each occupancy and site condition.

The following are descriptions of some typical quasi-judicial support functions.

Reception and Waiting Areas

A secure reception area with seating is typically provided adjacent to the main entrance or elevator lobby as appropriate to provide the visibility and accessibility required by the particular operation.

These spaces are provided in support of hearing room functions. They are the main point of entry for claimants, appellants, their family, friends, counsel and others involved in the hearing process. They must accommodate a reception desk or counter, seating and coat storage as required by average client volumes and adequate

circulation space. In some cases, a security officer may be accommodated within or adjacent to the reception area to oversee activities and traffic flow.

Multi-floor occupancies are typically served by one large reception area.

Maximum area: to suit (within space allocation standards)

Floor finish: resilient, ceramic tile or base building standard carpet to suit operational and site conditions

Wall finish: paint and/or wall covering or unfinished to suit substrate

Lighting: base building

Counsel Rooms/Interview Rooms

See [section C4.1](#) for a drawing that illustrates the typical size and configuration of a counsel/interview room. These rooms may also be referred to as mediation or deliberation rooms and are intended for the use of claimants or appellants and their counsel prior to the start of a hearing. One or more of these rooms may be provided for a variety of similar functions that typically involve a one-on-one or two-on-one exchange or gathering and recording of information.

Maximum area: 14 m²

Floor finish: base building standard carpet

Wall finish: paint or unfinished to suit substrate

Lighting: base building with separate switching

Quasi-judicial Work Rooms

These rooms are provided for a variety of related functions e.g., breakout rooms, alternative dispute resolution rooms, case preparation rooms, case review rooms, tactical rooms and appointees' rooms. They should be sized to suit the particular capacity required, and fit up as meeting rooms.

Employee Washrooms

See [section C4.2](#) for drawings that illustrate the typical size and configuration for employee washrooms. A dedicated accessible two-piece washroom is provided where public access to base building washrooms present security concerns for the employees.

Maximum area: as required to meet CAN/CSA B651 *Accessible Design for the Built Environment*

Floor finish: ceramic tile

Wall finish: ceramic tile and paint or unfinished to suit substrate

Lighting: base building with separate switching

Waiting Rooms/Detention areas

These rooms may be required (based on a threat and risk assessment) to maintain control of detainees brought to attend a hearing. The detainees are held in these rooms for short periods of time prior to or following a hearing and during breaks. The size and type of detention area varies. It may consist of an individual holding room only or also require a security guard area and/or separate washroom.

Maximum area: to suit (within space allocation standards)

Floor finish: base building standard carpet

Wall finish: paint or unfinished to suit substrate

Lighting: base building with separate switching

C3. Planning

C3.1 Planning and Design

The planning and design principles described in [section A1](#) and the *GCworkplace Design Guide* are to be applied, to the greatest extent possible, to quasi-judicial accommodation. Opportunities for collocation with similar organizations should be considered and encouraged, where appropriate.

Security Requirements

Security requirements are of particular importance in the context of quasi-judicial accommodation. They must be based on a threat and risk assessment, highlighted at the project definition phase, well defined during the project identification stage, and signed off by the departmental security officer. This will ensure the acquisition of appropriate space and the development of optimal layouts.

Dual circulation is a security based requirement common to many quasi-judicial accommodations. Additional entry points and corridors may be required for some quasi-judicial occupancies to separate public (e.g., hearing and mediation rooms) from private (employee) areas and, in some cases, to provide alternative passage for different client groups (e.g., victims and offenders, witnesses and accused). For similar reasons, some quasi-judicial hearing rooms require two means of entry/exit. The space allocation standards should, in most cases, accommodate dual circulation requirements.

The following sample floor plans illustrate these planning considerations as applied to the standard allocations for quasi-judicial accommodation and support space.

C4. Sample Detail Drawings

C4.1 Support Space

GIC Appointee Enclosed Offices

Examples of Enclosed Office Layouts
10 m² (100 ft²)

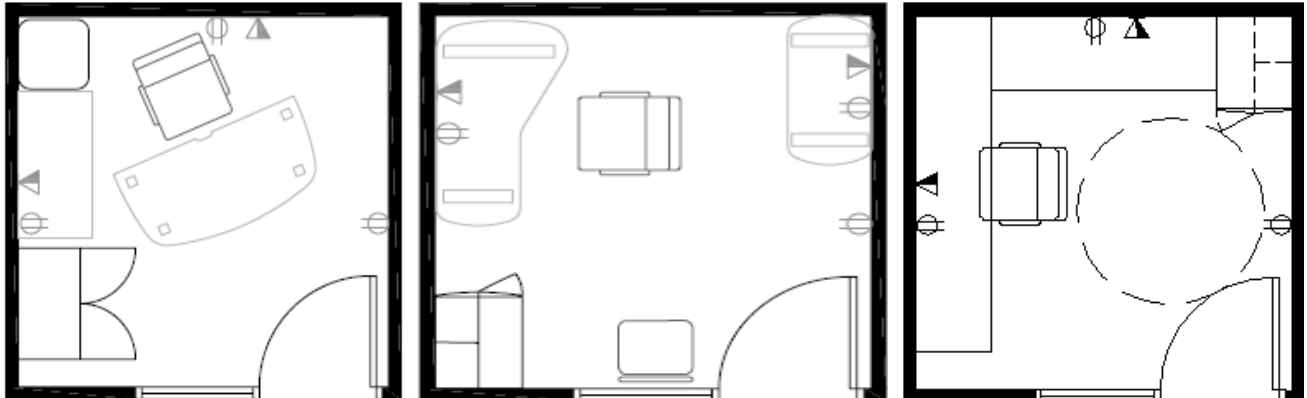

Note: This example provides for fully accessible office.

Examples of Enclosed Office Layouts
14 m² (150 ft²)

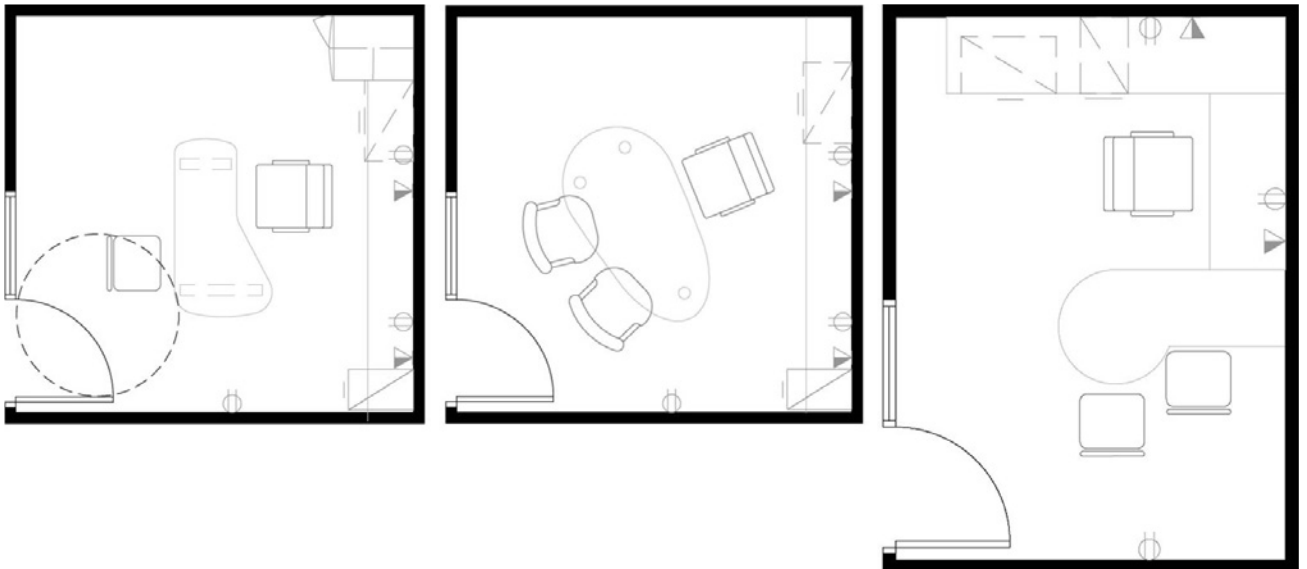

Note: This example provides for fully accessible office.

Summary

Offices accommodate average requirements for work surfaces, shelving, storage and filing. Furniture can be freestanding or hung from reusable partition systems.

Note: Furniture layouts are provided as examples and may vary.

Standard Finishes

- Floor—base building standard carpet (carpet tile or rolled goods)
- Walls—paint or unfinished to suit substrate (*Note:* partitions may be traditional construction or reusable partition systems (e.g., movable, demountable) see [section A3.2.](#))

Standard Electrical Requirements

- For 10 m² offices, 3 standard electrical duplex receptacles per office (2 circuits)
- For 14 m² offices, 3 standard electrical duplex receptacles per office (2 circuits)
- Any circuit can be common for a maximum of four offices
- 2 image/voice/data outlets (*Note:* client to provide actual connectors and jacks, typically RJ45 with multiple jacks.)
- Base building lighting (may be relocated) with 1 separate switch/light control and dual technology motion sensor

Standard Mechanical Requirements

Interior zone:

- One (1) terminal unit with dedicated thermostat for every 2 offices
- Supply and return air diffuser(s)/grille(s)
- Acoustically lined transfer duct for full height partitions (slab to slab or slab-to-underside-ceiling-with-plenum-barrier)

Perimeter zone (where required):

- Dedicated thermostat with control of terminal units and perimeter system
- Supply and return air diffuser(s)/grille(s)
- Acoustically lined transfer duct for full height partitions (slab to slab or slab-to-underside-ceiling-with-plenum-barrier)
- Mechanical equipment and elements to be selected to support the room noise rating.

Typical Counsel/Interview Room Layout

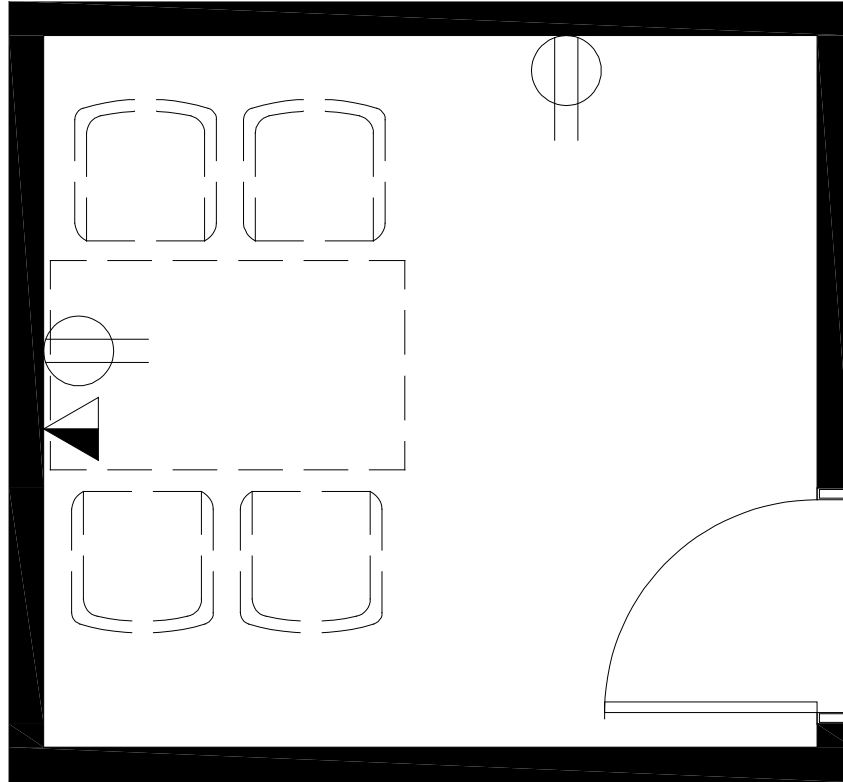

Summary

Space accommodates a small table and seating for 2 to 4. Configurations may vary.

Standard Electrical Requirements

- 2 standard electrical duplex receptacles
- 1 image/voice/data outlet (**Note:** client to provide actual connectors and jacks, typically RJ45 with multiple jacks.)
- separate switch/light controls as required

Standard Mechanical Requirements

- individual thermostat control c/w dedicated terminal units (VAV box, fan coil unit)
- supply and return air diffuser(s)/grille(s)
- transfer return air fan c/w on/off switch for full height partitions

C4.2 Typical Employee Washroom

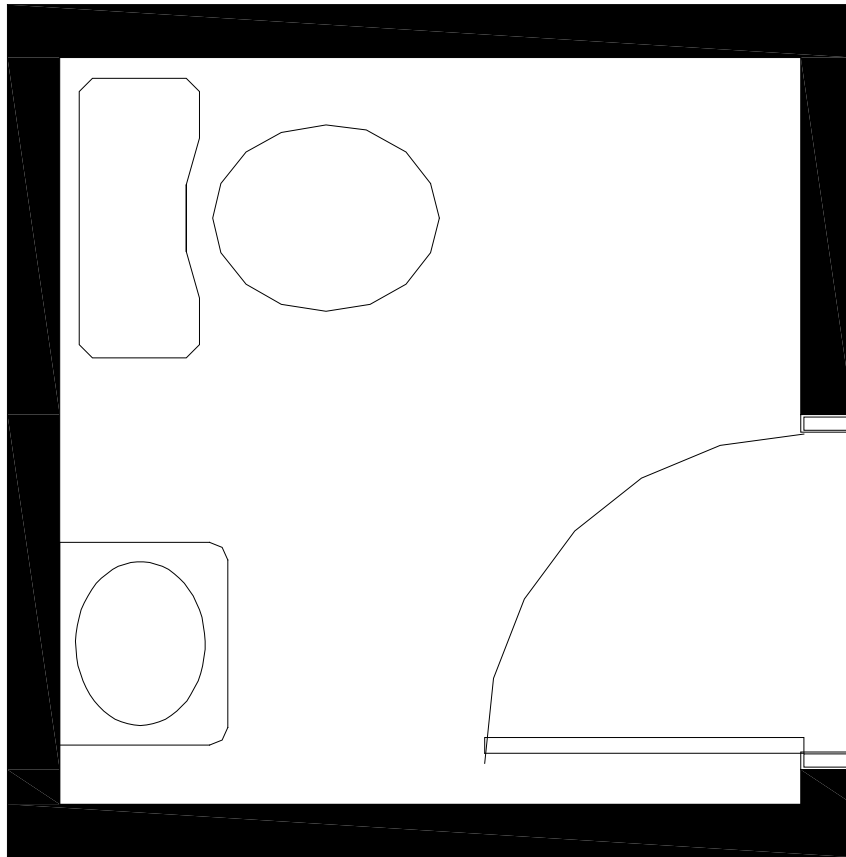

Summary

Area accommodates average requirements for a 2-piece washroom (basin and toilet). Accessories to include mirror, dispensers for paper towel, soap and toilet paper, and disposal receptacle(s). Grab bars to be provided as required to meet current accessibility standards. Fixtures, fittings and accessories are to match base building standard. Basin vanity or separate counter provided.

Standard Electrical Requirements

- no power provided

Standard Mechanical Requirements

- supply and return air diffuser(s)/grille(s)
- transfer return air fan c/w on/off switch for full height partitions
- exhaust c/w exhaust air grille
- water closet and basin c/w sanitary, vent, hot and cold water and insulation
- noise abatement as required
- transfer return air fan c/w on/off switch for full height partitions

C5. Costing

C5.1 Cost Estimates

Project managers and project officers are requested to follow the format shown in [section A7.1: Fit-up Cost Estimate](#) when preparing their cost estimates for fit-up projects. This breakdown will help to determine those types of fit-up elements that are more often associated with increased costs.



Section D: Call/Contact Centres Accommodations



D1. Introduction

D1.1 General Information

Overview

This section has been developed to address the special fit-up requirements of call/contact centre accommodation as provided by PSPC in accordance with the *Accommodation Management Framework*. It defines the quantity and quality (the “bundle of goods”) of fit-up elements that may be provided within the existing space allocation standards for general administrative office space functions.

Call/contact centres are based on the generic approach of the standards for general administrative office space in [section A](#) with some additional allowances to meet the special operational requirements of call/contact centres. The most notable are the provision of additional hard walled support spaces, and the provision of lunchroom/lounges/kitchenettes with lounge space, doors, the allowance for high-density acoustic ceiling tiles, direct and indirect lighting and the allowance for the partial use of glazed furniture panels.

These allowances are described in [section D2.2: Office and Support Space Allocations](#) and [section D3.1: Planning and Design](#), and provide increased flexibility to customize call/contact centre space to suit particular program requirements.

D1.2 Application

This section applies to federal call/contact centre office space. Call/contact centre office space is used by certain departments and agencies in support of a mandate to respond to a high volume of enquiries regarding their programs and services.

The functions of organizations that are call/contact centres include: responding to the public and public servants about specific government initiatives or ongoing programs and services; and processing requests for services or information. These functions primarily involve telephone contact with members of the public and employees and services may also be provided until late in the evening and on weekends. Training is ongoing due to a high turnover of staff and the requirement to update staff about new programs and program changes.

Key points of clarification when managing accommodation for call/contact centres include:

- Most departments and agencies have some type of public contact function. Call/contact centres refer to specific organizations within departments whose mandate is to respond to a high volume of calls on programs and services. Therefore, client departments are not universally categorized as being “call/contact centres”, but rather as departments that require some call/contact centre office space to execute their federal mandate.
- Call/contact centre office space is not limited to particular buildings or regions, but rather to certain occupancies.
- Call/contact centres are also characterized by the high degree of specialized technology required to operate their activities.
- Call/contact centre office space is a type of general-purpose office space, although, call/contact centre offices may also have unique space requirements.

D2. Standards

D2.1 Fit-up Elements and Funding Accountabilities

The following chart identifies fit-up elements and funding accountabilities related to the special fit-up requirements for call/contact centre office space. All standard fit-up elements not included in this chart are provided and funded in accordance with the general administrative office space. PSPC is responsible for initial fit-up of the space based on the functional and operational requirements of the end user. Changes to existing offices during the term of the occupancy are funded by the department or agency as a tenant service.

A. Interior Construction

Elements	PSPC Funded	PSPC Funded in Non-reimbursing Occupancy	Other
1. Partition Walls			
(a) Public Reception and Waiting Area slab to underside of ceiling with insulation (standard speech privacy).			Yes ¹
(b) Coaching/Interview rooms-slab to underside of ceiling with insulation (enhanced speech privacy).			Yes ¹

1. Client cost—**NOT** subject to the non-compliance approval process. Security requirements must be based on a Threat and Risk Assessment (TRA), Security Design Brief or Security Site Brief, signed off by the Departmental Security Office (DSO) and properly documented on the project file.

B. Interior Construction

Elements	PSPC Funded	PSPC Funded in Non-reimbursing Occupancy	Other
1. Doors and frames			
(a) Kitchenettes			
(i) Flush, solid core wood door, standard height and width (6'-8" or 7'-0" × 3'-0" wood veneer or paint finish w. door sweep).		Yes	
2. Interior Finishes			
(a) Office and Support Areas			
(i) Ceiling Finishes			Yes ¹
• High density acoustic tile.			
(ii) Floor Finishes			Yes ¹
• Raised floor systems and ramps, epoxy or other special treatments to suit client requirements.			

1. Client cost—**NOT** subject to the non-compliance approval process. Security requirements must be based on a Threat and Risk Assessment (TRA), Security Design Brief or Security Site Brief, signed off by the Departmental Security Office (DSO) and properly documented on the project file.

C. Furnishings and Equipment

Elements	PSPC Funded	PSPC Funded in Non-reimbursing Occupancy	Other
1. Furniture and Equipment			
(a) Furniture and Equipment			
(i) Panels/screens complete with service poles (midrange quality element system, non-acoustic class with power/data capability).		Yes	
(ii) Panels/screens with partial glazing. See section D2.3.		Yes	

D. Services

Elements	PSPC Funded	PSPC Funded in Non-reimbursing Occupancy	Other
1. Plumbing Systems			
(a) Dishwasher, energy efficient, commercial style			Yes ¹
2. Electrical Systems			
(a) Lighting			
(i) Modifications to base building fixtures to include direct and indirect lighting fixtures.			Yes ¹
(ii) Sound masking		Yes	

1. Client cost—**NOT** subject to the non-compliance approval process. Security requirements must be based on a Threat and Risk Assessment (TRA), Security Design Brief or Security Site Brief, signed off by the Departmental Security Office (DSO) and properly documented on the project file.

D2.2 Office and Support Space Allocations

This section describes standard provisions for typical call/contact centre office and support space allocations. These allocations must be managed within the *Space Allocation Standards* for general-purpose office space. Office and support spaces beyond those that can be accommodated within the standard call/contact centre office space allocation will be considered non-compliant and subject to the Approvals and Governance Process outlined in [section A2](#).

Office Space

Open Workstations

A single floor, open plan, is the preferred type of office space for call/contact centres. Open workstations, adaptable to team or individual configurations, are assigned to all personnel in open plan call/contact centre environments. Workstation sizes vary according to specific site conditions and functional requirements of the space. As call/contact centres require a high number of employees to carry out their functions, smaller workstations are typical. Call/contact centre employees are typically required to be at their workstations for 90% of the day, and equipment may include two monitors. Workstation sizes will vary to suit the needs of the organization but will not exceed 3.7 m² for agents. Workstations for supervisors, quality assurance, information technology, phone traffic control and administrative staff will not exceed 5.9 m². Part time/shift workers are to share workstations where possible. Possible workstation configurations are outlined in [section D4.1](#).

Support Space

Call/contact centres require common support spaces outlined in [section A](#) and the *GCworkplace Design Guide*, however the allocation of support space differs due to the higher number of employees and type of work. Call/contact centres typically require spaces to support extensive training activities and provide adequate kitchen, eating and lounge areas for staff working on various shifts with short meal periods. As workstations may be shared, and storage within workstations is limited, locker rooms are required. Due to the high number of employees per supervisor and the high level of turnover of staff, coaching rooms are required to provide feedback to employees and staffing reception areas are required to support recruitment. The type, quantity, size, configuration and placement of these spaces will vary with each occupancy and site condition.

The following allocations are provided for call/contact centre support space:

Meeting Rooms

Meeting rooms provide enclosed spaces for meetings, presentations, collaborative work and recruitment drives. Retractable walls between training and meeting rooms are recommended to provide additional flexibility. The following table summarizes provisions for meeting rooms for various population ranges.

FTEs per call/contact centre	Size of Meeting Room			Total
	Small 30 m ² seats 12	Medium 50 m ² seats 18	Large 60 m ² seats 20+	
25–50	–	1	–	1
51–75	2	–	–	2
76–100	2	1	–	3
101–125	1	2	–	3
126–150	1	1	1	3
151–175	–	2	1	3
176–200	–	1	2	3

Maximum area: to suit requirements (within space allocation standards)

Floor finish: base building standard carpet

Wall finish: paint and/or unfinished to suit substrate

Lighting: base building

Training Rooms

Due to turnover of staff and frequent changes in programs and services, training is an on-going requirement for call/contact centres. As some call/contact centres experience seasonal fluctuations, areas that can be quickly converted from training rooms to workstations are desired. Retractable walls between training and meeting rooms are recommended to provide additional flexibility. Freestanding, mobile furnishings are recommended. Raised flooring may facilitate conversion of training rooms.

Allocations for Training Rooms

FTEs per call/ contact centre	Number of Training Rooms	Size of Training Room
25–50	1	30 m ²
51–125	1	40 m ²
126–225	2	68.8 m ²
Over 225	2	85 m ²

Maximum area: to suit requirements (within space allocation standards)

Floor finish: base building standard carpet

Wall finish: paint and/or unfinished to suit substrate

Lighting: base building

A sample layout of a call/contact centre training room is included in [section D4.2](#).

Coaching/Interview Rooms

Most call/contact centre supervisors are responsible for 10–15 agents and each agent is assessed several times per month. Coaching/interview rooms provide space for one-on-one coaching and to address particular employee needs. Coaching rooms may also be used to conduct interviews with potential staff. Allocations for interview rooms are as follows:

FTEs per call/ contact centre	Number of 10 m ² spaces
25–50	1
51–75	2
76–100	3
101–150	4
151–200	5

Maximum area: 10.0 m²

Space accommodates typical office desking, storage and seating for four people. Data lines are required to facilitate coaching on systems. Configurations may vary. Space must meet CAN/CSA B651-12 *Accessible Design for the Built Environment*.

- Floor finish:** base building standard carpet
Wall finish: paint or unfinished to suit substrate
Lighting: base building with separate switching

A typical layout of a coaching/interview room is included in [section D4.2](#).

Lunchroom/Lounge/Kitchenette

Due to the number of staff, extended hours and short lunch periods, lunchroom facilities must be adequate to accommodate both food preparation, vending machines, and an eating area. Counter space must be sufficient to accommodate multiple microwaves, coffee makers and other equipment. Lounge space may be provided to allow for collaborative spaces for employees to relax and socialize, as personal interaction is typically not permitted in the call/contact centre service areas. Lunchroom areas may be combined to create larger areas depending on site conditions.

FTEs per call/ contact centre	# and size of areas	Lin. mm of counter and upper/lower stor- age in each area
25–50	one 40–60 m ²	4,800 (16')
51–75	two 40–60 m ²	4,800 (16')
76–100	two 40–60 m ²	4,800 (16')
101–150	two 40–60 m ²	4,800 (16')
151–200	three 40–60 m ²	4,800 (16')

See [section D4.2](#) for a drawing that illustrates the typical provisions for a lunchroom/lounge/kitchenette including descriptions of standard finishes and mechanical and electrical provisions.

Entrance doors are permitted on call/contact centre kitchenettes in order to reduce noise transfer to the call/contact centre work area.

Locker Areas

Due to the large number of staff, size of workstation and the fact that workstations may be shared, locker areas for storage of personal items are required.

Allocation of locker rooms is as follows:

FTEs per call/ contact centre	Number of 14 m ² spaces
25–50	1
51–125	2
126–200	3

See [section D4.2](#) for a typical locker area layout including descriptions of standard finishes and mechanical and electrical provisions. Locker areas would ideally be located near the entrance and kitchen areas.

Shared Equipment Areas

Shared equipment areas may be open or semi-enclosed but entrance doors are not provided. The following summarizes provisions for shared equipment areas for various population ranges:

FTEs per call/ contact centre	# and size of areas	Lin. mm of counter and upper/lower stor- age in each area
25–50	one 10–14 m ²	2,400 (8')
51–100	two 10–14 m ²	2,400 (8')
101–150	three 10–14 m ²	2,400 (8')
151–200	four 10–14 m ²	2,400 (8')

See [section D4.1](#) for a drawing that illustrates the typical provisions for a shared equipment area including descriptions of standard finishes and mechanical and electrical provisions.

Quiet Rooms

These are spaces intended for the shared use of personnel who normally occupy open workstations. They provide an enhanced acoustical environment for a private telephone call, to support work requiring a high level of concentration, or similar functions. The following table summarizes provisions for quiet rooms for various population ranges:

FTEs per call/ contact centre	Number of 5 m ² spaces
25–50	1
51–100	2
101–150	3
151–175	4
176–200	5

See [section D4.1](#) for a drawing that illustrates the typical provisions for quiet rooms including descriptions of standard finishes and mechanical and electrical provisions.

Reception and Waiting Areas

A reception area with seating is typically provided adjacent to the main entrance or elevator lobby.

These spaces are provided for the public attending recruitment drives or interviews. These spaces accommodate, seating and coat storage as required by average volumes and adequate circulation space.

Multi-floor occupancies are typically served by one large reception area.

Maximum area: to suit (within overall space allocation standards)

Floor finish: resilient, ceramic tile or base building standard carpet to suit operational and site conditions

Wall finish: paint or unfinished to suit substrate

Lighting: base building

Other Support Spaces

Call/contact centres may also have requirements for specialized telecommunications equipment. Dedicated equipment or telecommunications rooms will be provided to suit as required within overall space allocation limits.

D2.3 Standards for Furniture Panels/Screens

Panels are used to provide visual privacy in open-plan office environments. Panel height, classification and finish are described below. The nature of call/contact centre work requires that there be visual contact between team members and with team leaders and managers. At the same time, there is a need to maintain as much acoustic privacy as possible.

For call/contact centres glazed panels with a maximum height of 38 cm (15”) are allowed as required for visual contact within the call/contact centre as long as the overall maximum height is not exceeded. Fully glazed panels and sliding panels do **NOT** comply with the standards.

Clients may also purchase accessory items such as mobile whiteboards or add-on translucent or mesh dividers/toppers to create visual privacy with lower screen heights (maximum screen height cannot be exceeded).

A sample layout of call/contact centre workstations is found in [section D4.1: Typical Workstation Configurations](#).

Freestanding furniture with height adjustable work surfaces is recommended. The ergonomic features of chairs and keyboard trays must be carefully assessed when selecting furniture.

Panels shall meet the *Purchase Description for Workspaces* published by the Acquisitions Branch. The following additional restrictions apply to panel height, classification and finish options. See [section A5.1](#) and the *GCworkplace Design Guide* for planning and workplace design principles.

Height

The maximum height for panels is 1.37 m (54"). Lower panels allow for increased light distribution and airflow and provide seated privacy. Panels that exceed 1.37 m (54") are considered non-compliant.

Classification

Panels shall be non-acoustic class. High performance acoustical panels do **NOT** comply with the Standards.

Finish

Panel finish can be fabric upholstered, metal, veneers (wood) and plastic laminate as long as there is no cost differential. All materials shall be manufactured from recycled or other environmentally appropriate materials that respect the selection criteria identified in [section A5](#), unless reusing or matching existing panels. Glass panels with a maximum height of 610 mm (24") are allowed but the overall maximum screen height cannot be exceeded. Fully glazed panels and sliding panels do **NOT** comply with the Standards.

D3. Planning

D3.1 Planning and Design

The planning and design principles described in [section A1](#) and the *GCworkplace Design Guide* are to be applied, to the greatest extent possible, to call/contact centre accommodation. These principles provide the flexibility to meet the requirements of an organization.

Workstation Layout

A positive work environment is required to attract and retain employees to call/contact centre positions. As call/contact centre agents are required to be at their workstations for the majority of the day, access to natural light and exterior views, as well as visual contact with colleagues and supervisors is critical. Workstations with lower screens and some glazing are preferred. Ergonomic, height adjustable work surfaces and ergonomic chairs and keyboards are recommended. Acoustic control can be improved by arranging agent and supervisor workstations so cross transference of noise is minimized, and by including a sound masking system. Agent workstations should have easy access to water fountains and washrooms to minimize time away from the workstation.

Supervisor workstations should be within visual contact of call/contact centre agents. Supervisors should have easy access to interview rooms to provide feedback and private instruction to agents.

Meeting and Training Rooms

Freestanding, mobile furnishings are preferable for meeting and training rooms to provide for maximum flexibility. Meeting and training rooms should be designed to have the flexibility to use as agent stations during peak periods.

Retractable partitions may be considered for use within meeting and training rooms.

Locker Rooms and Shared Equipment Areas

Staff locker rooms should be located in open areas, ideally close to the entry and the kitchenette. Shared equipment areas should be located as far from agent workstations as possible.

The following sample floor plan illustrates these planning considerations as applied to the standard allocations for call/contact centre office and support space.

D3.2 Sample Plan

Planning Notes and Legend for PL1 Diagram

General Information

Total usable space: 1,829 m² (19,687 ft²)

Total FTEs: 175 (170 workstations, 5 closed offices)

Space per FTE: 11 m²/FTE (118.40 ft²/FTE)

Total open areas: 1,380 m² (14,854 ft²)

Total enclosed areas: 449 m² (4,833 ft²)

Open/closed ratio: 75%/25%

List of Support Spaces

- 3 meeting rooms
- 3 shared equipment/mail area
- 5 quiet rooms
- 1 kitchenette with lounge
- 1 printer/fax/file areas

List of Contact Centre Support Spaces

- 5 coaching rooms
- 1 reception area
- 3 locker area
- 3 training rooms

PL1 Diagram

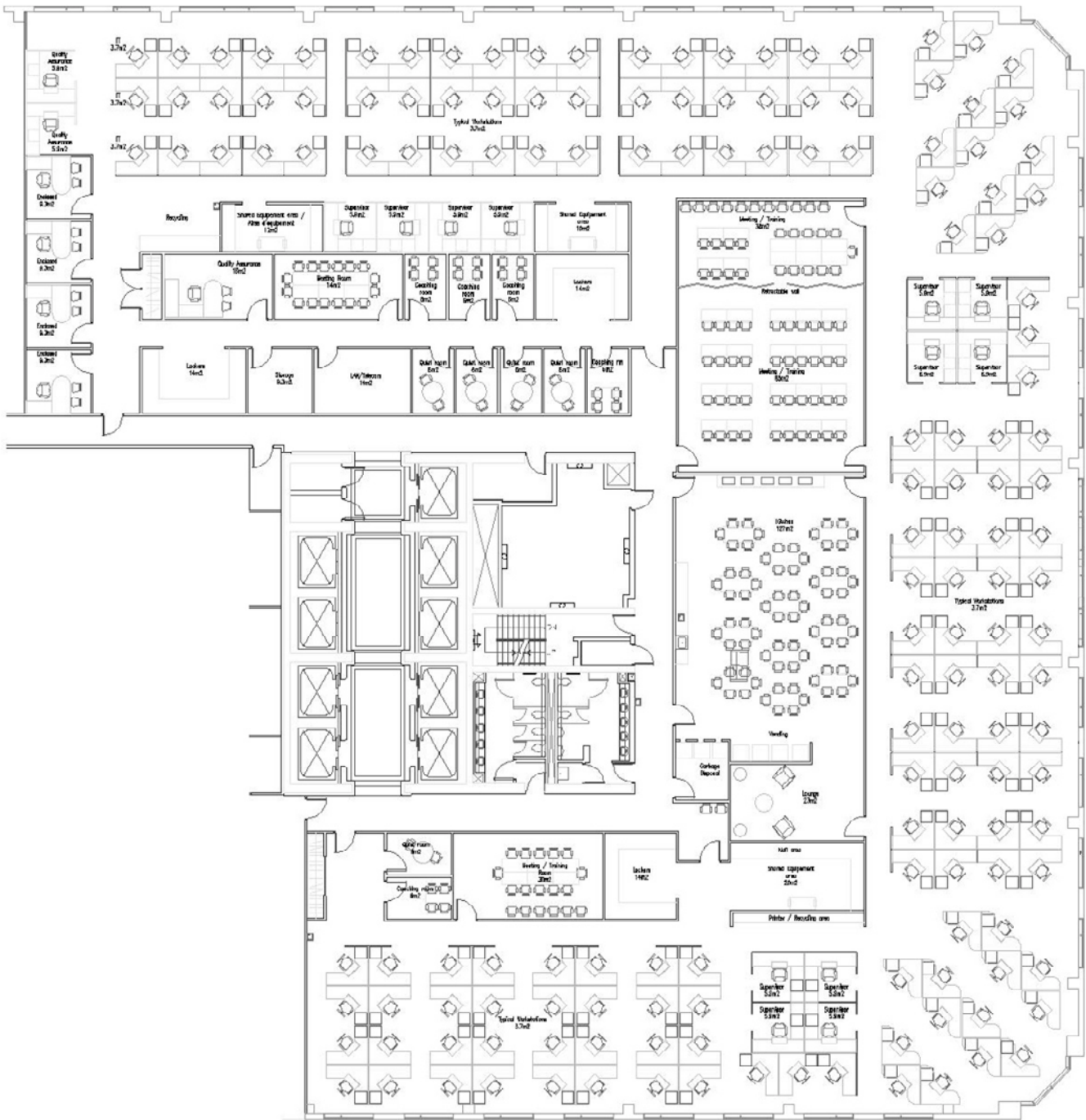

D4. Sample Detail Drawings

D4.1 Typical Workstation Configurations

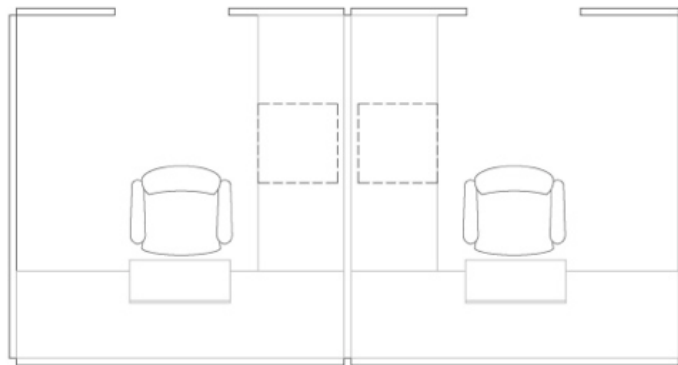
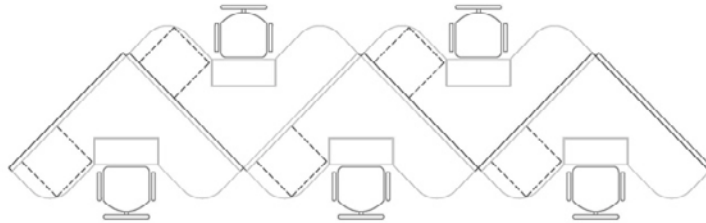
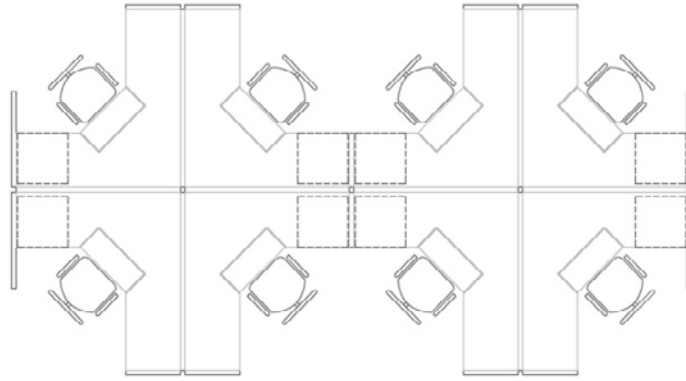

D4.2 Support Space

Typical Training Room

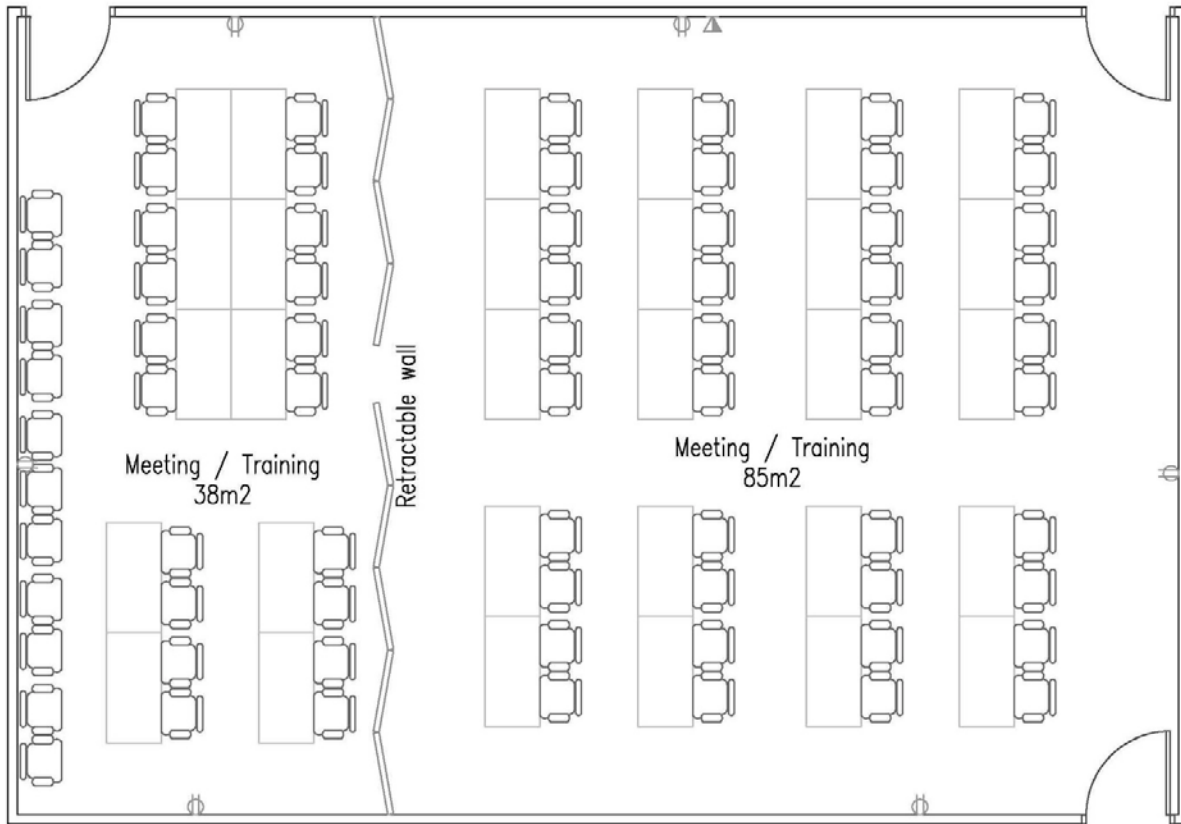

Summary

Space accommodates typical training tables and seating. Configurations may vary.

Standard Finishes

- Floor—base building carpet
- Walls—paint or unfinished to suit substrate

Standard Electrical Requirements

- standard electrical duplex receptacles to suit equipment needs
- image/voice/data outlet to suit equipment needs (**Note:** client to provide actual connectors and jacks, typically RJ45 with multiple jacks.)
- separate switch/light controls as required

Typical Coaching/Interview Room Layout

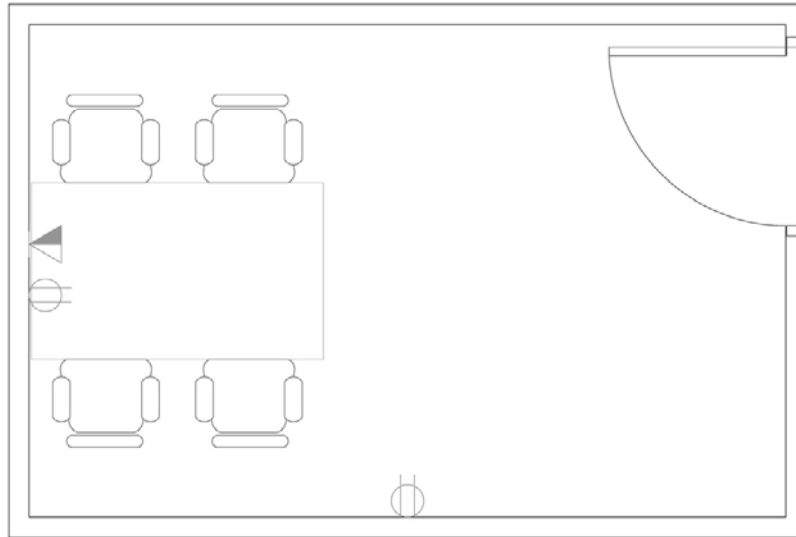

Summary

Space accommodates a small table and seating for 2 to 4. Configurations may vary.

Standard Finishes

- Floor—base building carpet
- Walls—paint or unfinished to suit substrate

Standard Electrical Requirements

- 2 standard electrical duplex receptacles
- 1 image/voice/data outlet (**Note:** client to provide actual connectors and jacks, typically RJ45 with multiple jacks.)
- separate switch/light controls as required

Standard Mechanical Requirements

- Individual thermostat control c/w dedicated terminal units (VAV box, fan coil unit)
- Supply and return air diffuser(s)/grille(s)
- Transfer return air fan c/w on/off switch for full height partitions

Typical Lunchroom/Lounge/Kitchenette

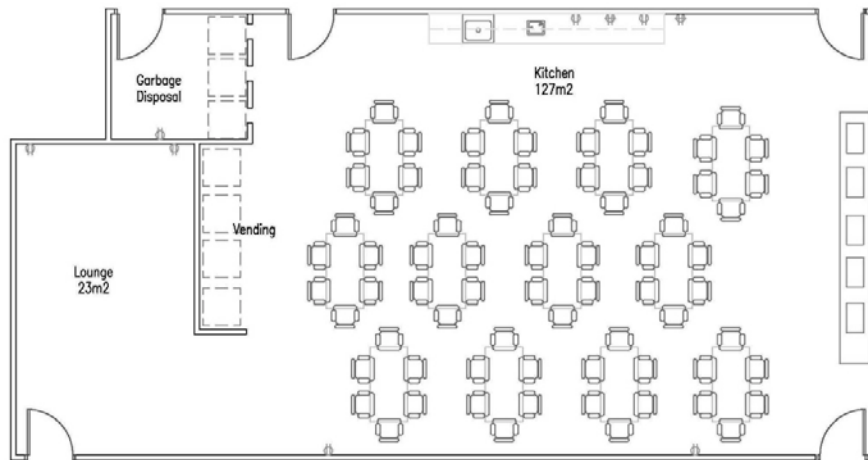

Summary

Area accommodates tables, seating, average storage requirements, recycling centre and trash as well as full size fridge(s) and countertop appliances (appliances not included). Design allows for barrier-free access to sink. Millwork for upper and lower cabinets is provided.

Standard Finishes

- Floor—resilient sheet or tile
- Walls—paint or unfinished to suit substrate
- Millwork—See [section A5.1: Finishes](#)

Standard Electrical Requirements

- 2 standard dedicated circuit duplex receptacles (microwave and fridge)
- 2 standard split circuit duplex receptacles for other countertop appliances (additional receptacle may be provided if required)
- Base building lighting with motion sensor
- 1 separate switch/light control for under cabinet lighting
- 1 receptacle for dishwasher if required

Standard Mechanical Requirements

- Hot water, cold water, drain and vent piping for kitchen sink
- Kitchen exhaust fan c/w on/off switch (exhaust to exterior if economical and feasible)
- Supply air diffuser(s) and grilles(s)
- No return air to base building system

Typical Locker Room

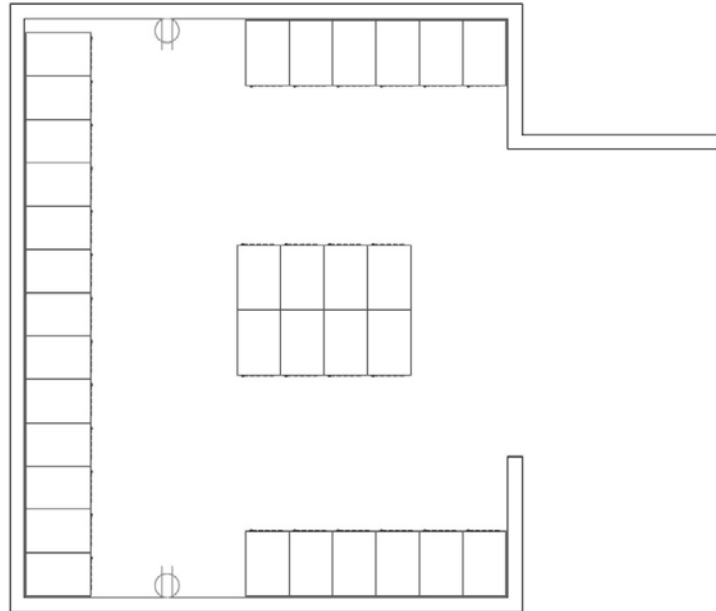

Summary

Space accommodates lockers to suit size of room. Configurations may vary.

Standard Finishes

- Floor—resilient sheet or tile
- Walls—paint or unfinished to suit substrate

Standard Electrical Requirements

- 2 standard electrical duplex receptacles
- Base building lighting with motion sensor

Standard Mechanical Requirements

- Supply and return air diffuser(s)/grille(s)

Shared Equipment Area

Example of Shared Equipment Area Elevation

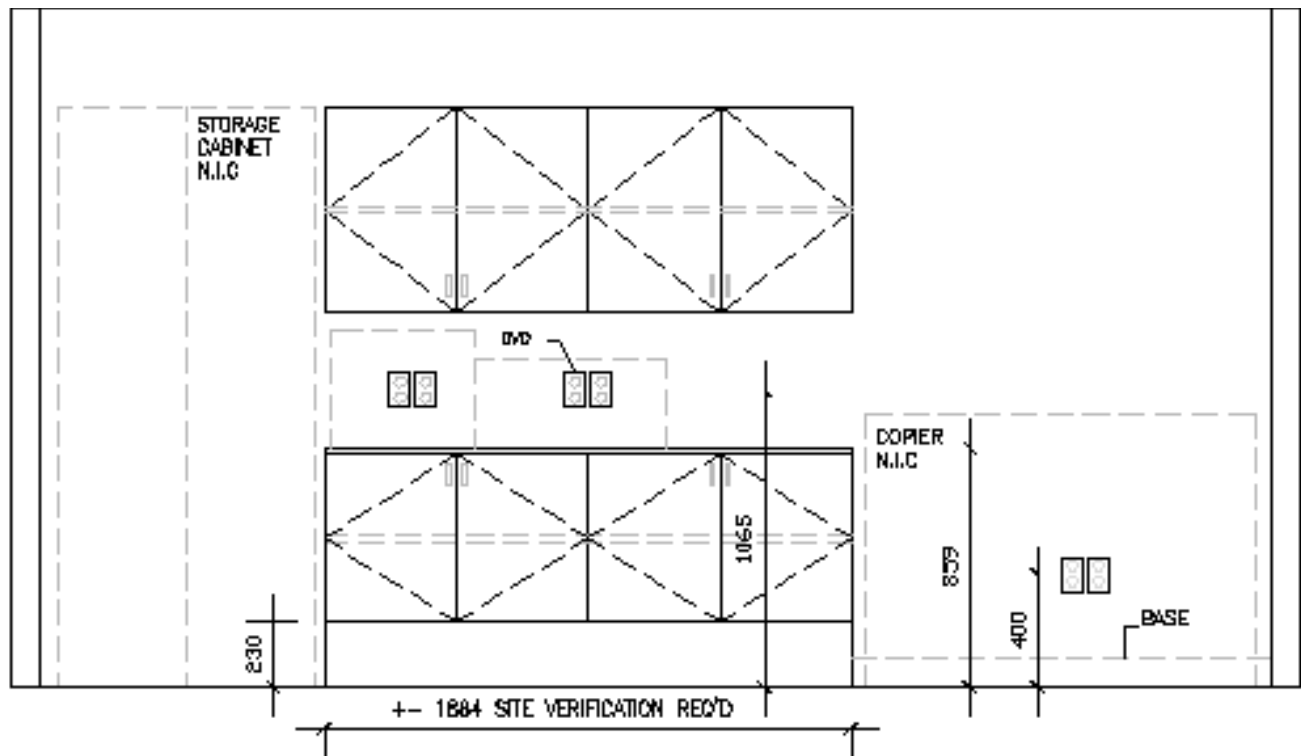

Summary

Area accommodates average requirements for storage, photocopier, printer and fax. Millwork for upper and lower cabinets is provided and can be a freestanding manufactured solution if there is no cost differential. See [section A3.2: Fit-up Elements and Funding Accountabilities](#) for further details. Storage cabinet and equipment not included.

Standard Finishes

- Floor—resilient sheet or tile or base building standard carpet
- Walls—paint or unfinished to suit substrate
- Millwork—See [section A5.1: Finishes](#)

Standard Electrical Requirements

- 4 electrical duplex receptacles to meet specific equipment needs
- 3 image/voice/data outlets (*Note:* client to provide actual connectors and jacks, typically RJ45 with multiple jacks.)

Standard Mechanical Requirements

- Exhaust for photocopier to exterior
- Supply air diffuser(s) and grilles(s)

Quiet Room

5 m² (approximately 54 ft²)

Examples of Quiet Room Layout

5 m² (54 ft²)

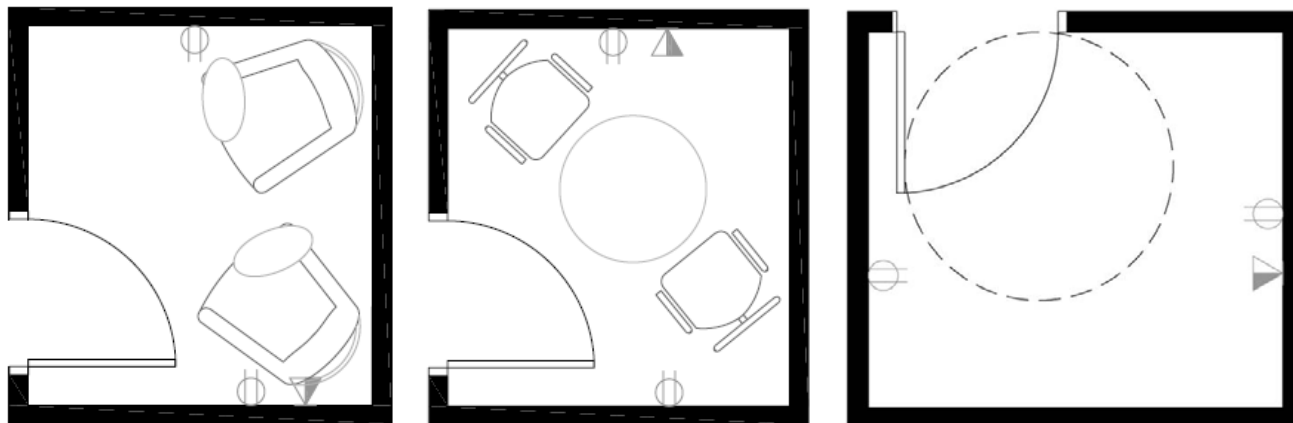

Summary

Quiet rooms accommodate freestanding work surfaces suitable for a computer and telephone and should be barrier free.

Standard Finishes

- Floor—base building standard carpet (carpet tile or rolled goods)
- Walls—base paint or unfinished to suit substrate

Standard Electrical Requirements

- 2 standard electrical duplex receptacles
- 1 image/voice/data outlet (**Note:** client to provide actual connectors and jacks, typically RJ45 with multiple jacks.)
- Base building lighting (may be relocated) with 1 separate switch/light control (task lighting recommended) and motion sensor

Standard Mechanical Requirements

- Supply and return air diffuser(s)/grille(s)

D5. Costing

D5.1 Cost Estimates

Project managers and project officers are requested to follow the format shown in [section A7.1: Fit-up Cost Estimate](#) when preparing their cost estimates for fit-up projects. This breakdown will help to determine those types of fit-up elements that are more often associated with increased costs.



Glossary



Glossary

Accommodation and Real Property Services Program

PSPC provides federal departments and agencies with affordable office and common use accommodation that supports the delivery of their programs and services. The department acts as steward for various public works such as buildings, bridges and dams, and national treasures such as the Parliamentary Precinct and other heritage assets across Canada. PSPC also provides other federal departments, agencies, and the Parliament of Canada with responsive and cost-effective real property services.

The Federal Accommodation sub-program provides for the accommodation needs of federal organizations by providing and maintaining a cost effective portfolio of office facilities, common use assets and special properties (predominantly conference and training facilities). This sub-program is composed of two primary activities: the provision, on an obligatory basis, of general-purpose accommodation and common use space to support the delivery of government programs; and optimization of real property investments in direct support of the provision of accommodation.

The Federal Holdings sub-program includes a diverse portfolio of federal facilities and activities under the purview of the Minister of PSPC that are grouped for reporting purposes: the stewardship and management of major engineering assets and wharves, as well as the development of strategies for their divestiture; the administration, capital management and leasing services for residential housing units in the Northwest Territories and Nunavut to support the delivery of federal government programs; appraisals for all acquisitions, dispositions and transfers of real estate, as well as the maintenance of related guidelines and policies; and, the authoritative interpretation of expropriation legislation and regulations and the implementation of the expropriation process on behalf of the federal government.

Activity-based Work/Activity-based Workplace

Activity-based work is undertaken in a workplace in which individual employees are not assigned to a particular workstation. This type of work environment is known as the activity-based workplace (ABW). The workspace is configured to provide employees with access to a variety of tools and resources within various work points allowing them to conduct specific tasks including learning, focusing, collaborating, socializing, etc., over the course of the workday. In an ABW employees may move freely between work points as needed. The ABW features modern technology in support of mobile, collaborative, independent and remote work. The ABW design is based on an assessment of the activity requirements of clients' and their employees' (front end planning process) in collaboration with PSPC.

Base Building

The building shell including finished floors, structure, exterior envelope, interior core and demising walls, finished ceilings complete with lighting, and other building systems consistent with the designed function and planned general use of the building. In the case of office accommodation, for example, the base building would include exterior window coverings and primary identification signage.

BMP (Building Management Plan)

The BMP is a facility-specific annually costed work plan. BMPs are developed consistent with Asset Management Plans (AMPs) and Community-based Investment Strategies (CBIS). The BMP will normally contain information on costs and revenues, trends, levels of service and planned projects. The BMP is a planning tool for initial allocation. Source: *Asset Management Plan Policy*.

Circulation Space

Space allowed for movement of personnel between workstations. It includes the space for access to support space and building services.

Cyclical Maintenance

Repair or replacement of standard base building and fit-up elements at the end of their useful life, on a cyclical basis (i.e. during fit-up/cyclical refit).

Expansion

Increase to the total space in a client department's inventory to accommodate program growth.

Expansion Control Framework (ECF)

Expansion space for non-reimbursing client departments that is beyond their space envelope limit and, therefore, is funded by client departments.

Fit-up for Initial Occupancy

The preparation of accommodation for initial federal occupancy in accordance with the *Government of Canada Workplace Fit-up Standards*. This fit-up may include alterations or improvements to the base building and/or base building systems, including demolition. A list of fit-up items that PSPC provides for initial occupancy is included in [section A3.2: Fit-up Elements and Funding Accountabilities](#).

Fit-up Rates

PSPC establishes fit-up rates for general purpose office space in major urban centres across the country. The rates are based on the cost of all standard fit-up elements. They are updated annually and are to be used as a budgeting mechanism when preparing cost estimates for fit-up projects for general administrative, public contact and quasi-judicial office space, and as a funding limit for fit-up projects for ministerial and deputy head accommodation. (See [section A6.1: Fit-up Rates \(Under Development\)](#).)

Floor Plate

The size and shape of the floor of a particular building.

Forced Move by PSPC

A PSPC initiated move required prior to the termination of an existing occupancy.

Functional Program

A detailed statement of the accommodation requirements of a client department or agency in relation to a specific fit-up or tenant service project. It supports the space allocation and fit-up standards by describing any qualitative and quantitative gaps between the standards and what is needed by a department or agency to perform its activities efficiently, effectively and safely. Requirements that do not comply with the standards are highlighted in the functional program and reconciled or addressed as non-compliant. A gap analysis identifies the differences between the stated requirements and fit-up standards. The data collected informs both the investment analysis and the planning and design process.

The scope of work of a functional program may include:

- Verification of project requirements;
- Project schedule;
- Risk management;
- Implementation strategies;
- Sustainability requirements;
- Workstation requirements;
- Support space requirements;
- Special purpose space requirements;
- Planning alternatives;
- Communication/data requirements;
- Security requirements;
- Proximity/adjacencies requirements;
- Detailed functional space equation;
- Scheduling requirements;
- Class “D” and “C” cost estimate;
- Schematic design;
- Vertical/horizontal zoning; and
- Other special requirements.

Functional programs are funded by PSPC when required for fit-up projects of non-reimbursing occupancies. Functional programs are funded by client departments when required for fit-up projects of reimbursing occupancies or for tenant service projects.

General Administrative Offices

Offices that accommodate general office functions and activities that do not require special security or other special features. General administrative offices do not have high interface with the public. These offices comprise the majority of PSPC office space occupied by client departments and agencies.

Heating, Ventilation and Air Conditioning (HVAC) Systems

Mechanical systems that supply or remove heat, supply or remove humidity, and supply outdoor air as required.

Kiosk

Small structure for display or dissemination of information.

Major Renovation

Work undertaken to correct or delay physical or functional obsolescence and/or to extend the useful or economic life of a building. Included are improvements to the building’s structure or systems, such as HVAC, lighting, elevators, sprinkler systems.

Occupancy Instrument (OI)

A formal agreement between a department or agency and PSPC concerning occupancy in a particular asset. It records the rentable and usable areas, the civic address and the planned general use of the particular parcel of accommodation that is subject to the agreement. It also records the terms and conditions that govern the provision and occupancy of the accommodation, as well as charges for accommodation and agreed upon services.

Office Space

Includes office/workstation areas, general support space and circulation for all four generic office types.

Public Contact Offices

Offices accommodating functions that provide face-to-face services to the public. Functions and operations may include, but are not limited to:

- inquiries from walk-in customers;
- training/testing/meetings; and
- application/form processing.

Purchase Order (PO) or Local Purchase Order (LPO)

A purchaser's written offer to a supplier, formally stating all terms and conditions of a proposed transaction.

Quasi-judicial Accommodations

Offices that accommodate adjudicative or legislative functions. They often require confidentiality or enhanced security and are used by organizations that interpret and administer legislation and regulations, conduct inquiries and hearings and/or perform adjudication functions on complaints, appeals and claims. Functions and operations may include, but are not limited to:

- management: adjudicative body operates separately from the administrative unit which provides service to the adjudicative body;
- meetings: conducted on a scheduled basis with internal staff and members of the public; and
- secure and confidential courtroom/hearing room space; physical protection of staff could be required.

Refit

The alteration of space previously occupied, to meet the requirements of a different federal organization in accordance with the *Government of Canada Workplace Fit-up Standards* (space assignment) **AND** the alteration of existing space because the fit-up elements have reached the end of their useful life. The scope of the fit-up for reuse is determined by taking into consideration the life cycle approach, the functional requirements of the new client, existing conditions of the previously occupied space, and the duration of the new occupancy.

Renewal

Renewal of an occupancy instrument or lease agreement at the end of its term to accommodate a client department's continuing requirement for space at the same location. The decision to renew an occupancy instrument or lease is based on an investment analysis. The new occupancy instrument or lease agreement may be for the same or a reduced amount of space. A renewal may also be combined with a client department's requirement for expansion.

Rentable Area

The space used to calculate rental payments. Rentable areas include usable areas and areas such as lobbies, wash-rooms and electrical rooms. Stairways, entrances and elevators or duct shafts are not included in rental areas. Under review.

Replacement

Transfer of existing space in a client department's inventory to a new location at the end of an occupancy instrument. The decision to replace existing space is based on an investment analysis. The relocation may be to new or existing space in the PSPC inventory.

Secure Administrative Offices

Offices accommodating activities which require enhanced levels of security. Functions and operations may include, but are not limited to:

- the review and storage of sensitive files; and
- little or no public contact.

Space Envelope

The total amount of rentable square metres departments can occupy by fiscal year based on authorities received by PSPC to provide accommodation in accordance with standards, policies and guidelines.

Space Optimization

An accommodation project to maximize the use of a finite quantity of space in an existing facility in accordance with the *Government of Canada Workplace Fit-up Standards*; thus reducing the space utilization rate per FTE. This results in densification in an effort to reduce current inventory levels and/or expansion avoidance and may take place either at the end of an OI or during an occupancy to accommodate additional FTEs as a result of a program expansion.

Special Purpose Space (SPS)

Additional, non-standard areas required by a client department to accommodate specific activities that are unique and essential to departmental programs.

Examples of special purpose spaces include, but are not limited to:

- laboratories, health units or clinics;
- meeting or training complexes which serve outside groups;
- interview rooms;
- inspection rooms;
- processing space;
- departmental libraries (e.g., Department of Justice libraries);
- gymnasiums, warehouses (e.g., PSPC's Seized Property Management Directorate warehouse space);
- very large file or storage areas other than allowed by the *Government of Canada Workplace Fit-up Standards* (e.g., Canada Revenue Agency (CRA) tax return file storage, Library and Archives storage);
- trade shops;
- large mailrooms (e.g., CRA's mailroom);
- computer training rooms;
- cash offices or similar spaces requiring special service and security features; and
- hearing rooms.

Specific Service Agreement (SSA)

An internal PSPC contract between one of the service branches and another government unit. It describes the work to be done, the schedule and the cost of the work.

Support Space

Spaces for office support functions not included in the workstation, or circulation space but necessary for office operation. Support space includes meeting rooms, quiet rooms, collaborative areas, kitchenettes, shared equipment areas, printer stations, reception/waiting areas, and other areas as described in [section A](#) and the *GCworkplace Design Guide*.

Swing Space

Temporary office space used to accommodate client departments while their long term office space is under renovations or until new office space is available. Minimal fit-up is required for swing space.

Task Lighting

Lighting oriented to or located at a task position is generally called task lighting. Task lights located at the task area are usually used in conjunction with ambient or general lighting and are client funded.

Tenant Services

Alterations to existing accommodation requested and funded by a client and carried out during the term of an occupancy.

Usable Area

Office floor area available to the tenant. Columns and such are not included in usable area.

Work authorization

Written order providing authorization to a contractor to proceed with the performance of a contract.

Workplace 2.0 (for historical reference)

This design concept was initially the basis for the framework for a modernized fit-up and served as the baseline standard for workplace modernization. Within this concept, workstations were fixed and typically assigned, with a prescribed number of support spaces and collaborative areas based on the number of employees in a given workplace. The use of modern technology, such as wireless connectivity and notebook computers were client funded options that were crucial to the success of the design.

Workpoint

The location(s) within the activity-based workplace from which an employee chooses to work. In an ABW, an employee may choose to work from several different work points over the course of the day depending on the task to be completed. Examples of work points include typical workstations with a desk and chair, a seat in the boardroom, an enclosed space, a seat in the kitchenette or a sofa/seat in an open collaborative space, etc.

Workstation

Area designated by either the arrangement of furniture, vertical panels or otherwise with equipment for the performance of a work activity.

